



MXA902

Integrated Conferencing Ceiling Array

User guide for Shure MXA902 integrated ceiling array microphone, loudspeaker, and IntelliMix DSP. Learn how to install and get great audio in small/medium rooms
Version: 0.4 (2024-E)

Table of Contents

MXA902 Integrated Conferencing Ceiling Array	4	Mute the MXA902	19
General Description	4	Use Designer's Auto Route	19
Features	4	Dante Channels	20
Getting Started	4	IntelliMix DSP	20
Videoconferencing Room Equipment	4	DSP Best Practices	20
MXA902 Designer Setup Example	6	Acoustic Echo Cancellation	21
MXA902 Web Application Setup Example	7	Noise Reduction	21
MXA902 Parts	8	Automatic Gain Control (AGC)	22
Power Over Ethernet Plus (PoE+)	10	Delay	22
Model Variations	10	Compressor	22
Optional Accessories and Replacement Parts	10	Parametric Equalizer	22
What's in the Box	10	Encryption	25
Reset Button	11	Set Up the 802.1X Protocol for a Device	25
Reset Modes	11	Turn Off or Clear 802.1X Settings	26
MXA902 Control Software	11	Change 802.1X Settings	26
Control Devices with Shure Designer Software	12	Troubleshooting 802.1X Setup Issues	27
Use HTTPS for Web Application	12	Networking Best Practices	27
Firmware Updates	12	Switch and Cable Recommendations for Dante Network- ing	27
MXA902 Coverage	12	Device IP Configuration	28
How Much Space Does the MXA902 Cover?	13	Setting Latency	28
Using Autofocus™ to Improve Coverage	13	QoS (Quality of Service) Settings	28
How to Install the MXA902	13	IP Ports and Protocols	29
Install in a Ceiling Grid	14	Digital Audio Networking	30
VESA Standardized Mounting	17	Compatibility with Dante Domain Manager	30
Suspending from the Ceiling	18	Dante Flows for Shure Devices	30
Install on a Ceiling with the A900-CM	18	AES67	31
Adjust Microphone and Loudspeaker Levels	18	Sending Audio from a Shure Device	31

Receiving Audio from a Device Using a Different Audio Network Protocol	31	Additional Resources	35
Paint Square Array Microphones	31	Specifications	35
Step 1: Remove the Frame and Grille	32	MXA902 Microphone Frequency Response	37
Step 2: Mask and Paint	33	Dimensions	38
Step 3: Reassembly	33	IMPORTANT SAFETY INSTRUCTIONS	38
Use Command Strings	33	Important Product Information	39
Troubleshooting	34	Information to the user	40
		Certifications	40

MXA902

Integrated Conferencing Ceiling Array

General Description

The Microflex® Advance™ MXA902 Integrated Conferencing Ceiling Array delivers premium audio capture and reproduction for small- to medium-sized meeting spaces—with virtually no setup required. It combines an advanced array microphone with an integrated loudspeaker for natural sounding speech reproduction. Features Single-Zone Automatic Coverage™ technology to capture audio from a 20 by 20-foot (6 by 6 meter) area and onboard IntelliMix® DSP for echo- and noise-free audio. Paintable white finish; versatile mounting options.

Features

- Array microphone and loudspeaker in one unit for premium sound with minimal installation time
- Single-Zone Automatic Coverage technology to capture audio from a 20 by 20-foot (6 by 6 meter) area out of the box
- Integrated 2.5-inch wide-dispersion loudspeaker for clear, intelligible speech reproduction
- Onboard IntelliMix DSP with acoustic echo cancellation, noise reduction, automatic mixing, AGC, and EQ for echo- and noise-free audio
- Square form factor available in 24-inch or 60 cm sizes with paintable white finish
- Versatile options for ceiling, pole, or wire rope suspension mounting
- Shure Designer System Configuration software for easy setup and configuration
- PoE+ powered
- LED status bar with configurable colors and brightness
- Dante & AES67 audio networking protocols

Getting Started

Videoconferencing Room Equipment

Your Microflex microphone is one part of a complete room system for videoconferencing. It's helpful to think about all the parts of your room system as you get started setting up the microphone.

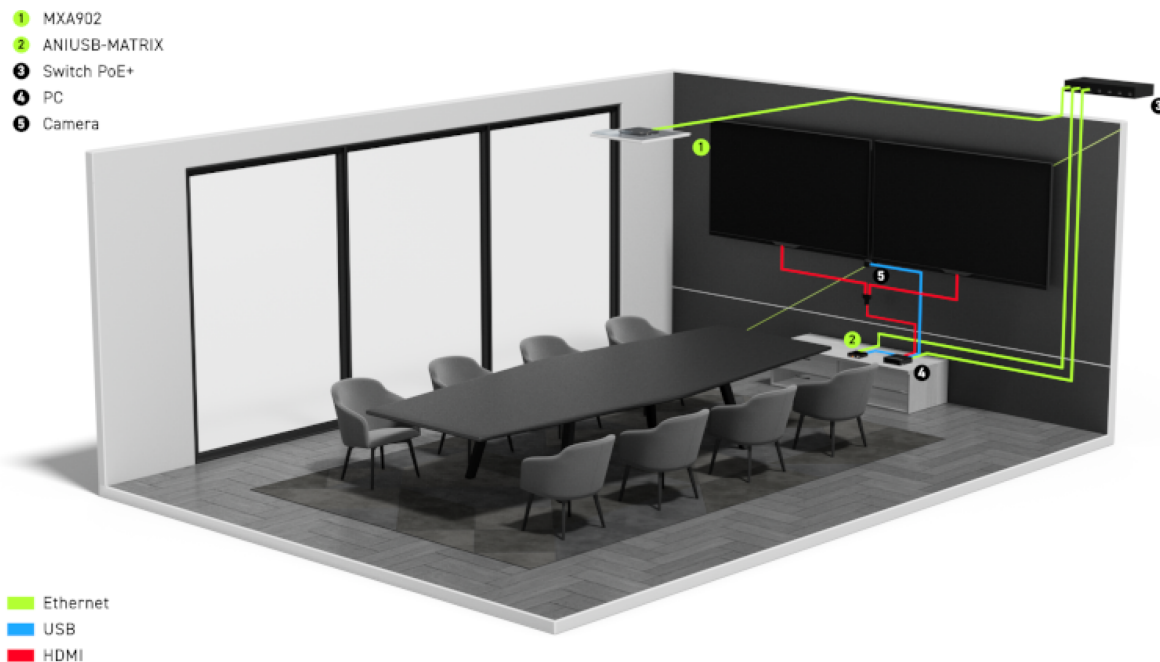

Medium room equipment example

A standard room includes some or all of this equipment:

- Microphone(s)
- DSP or other processor
- Loudspeakers (networked or analog)
- Computer with videoconferencing software
- Network switch
- Camera
- Other accessories such as table mute buttons, tablets to control meetings, and other peripherals

The [Microflex Ecosystem](#) offers a complete portfolio of networked audio solutions that can be precisely tailored to your needs.

What Software Do I Need to Set Up This Microphone?

Install this software on a computer that connects to the same network as the microphone:

- **Control software** to adjust microphone settings. This microphone has 2 options:

Option 1: [Shure Designer](#)

- Use for managing lots of Shure devices in 1 place
- Control Shure devices and route audio between them
- Create rooms to manage devices and design coverage

Option 2: Web application (open using [Shure Web Device Discovery](#))

- Use to manage each Shure device separately
- Control each device individually with its web application
- Route audio using [Dante Controller](#)
- **Dante Controller** to send audio signals to other Dante devices. Not necessary if you're only routing audio to Shure devices in Designer.
- **Shure Web Device Discovery** to easily find device web applications. Not necessary if you're only using Designer.

- **Shure Update Utility** to update firmware on Shure devices (download at shure.com/suu)

MXA902 Designer Setup Example

This example uses Shure Designer 6.0 software to set up an MXA902 and an ANIUSB-MATRIX. You can use other combinations of devices with the MXA902, but the setup process in Designer is similar.

After completing this basic setup process, you should be able to:

- Access the MXA902 in Designer
- Adjust DSP settings, route audio, and change loudspeaker levels
- Understand the basic workflow for working with devices in Designer

This example uses:

- Cat5e or better Ethernet cable (shielded cable recommended)
- [Network switch](#) that provides Power over Ethernet Plus (PoE+)
- Shure Designer software (download at shure.com/designer)
- ANIUSB-MATRIX
- Computer with videoconferencing software

Step 1: Install and Connect

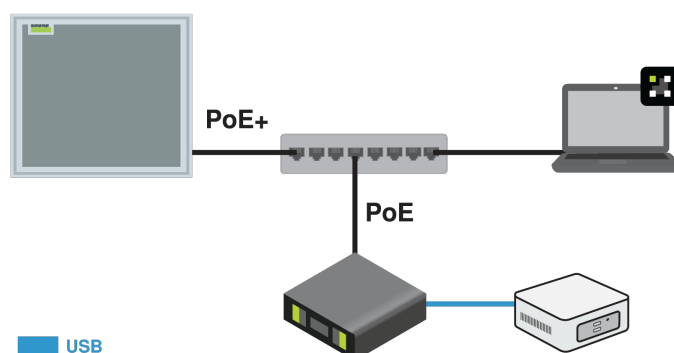

The MXA902 microphone and loudspeaker intelligently covers all talkers inside the 20 x 20-foot (6.1 x 6.1 m) coverage area. IntelliMix DSP sends a clear signal for the far end, with AEC, noise reduction, and more on a single output. The loudspeaker provides high-quality speech reproduction for the entire 20 x 20-foot (6.1 x 6.1 m) coverage area.

1. [Install the MXA902](#) and other devices. Connect the MXA902 to a PoE+ port on the network switch using Ethernet cable. If your switch doesn't supply PoE+, the loudspeaker does not play sound and the error LED flashes. The ANIUSB-MATRIX only requires PoE.
2. Connect a computer with videoconferencing software (such as Zoom or Microsoft Teams) installed on it to the ANIUSB-MATRIX's USB port.
3. Connect the computer running Designer to the same network.
4. Open Designer. Check that you're connected to the correct network in **File > Designer preferences**.
5. Open a new design and drag both devices into the design.

Step 2: Route Audio and Apply DSP

The easiest way to route audio and apply DSP is with Designer's auto route workflow. This feature routes audio signals, applies DSP settings, turns on mute synchronization, and enables LED control for connected devices.

1. Select Auto route. Designer makes the following routes:
 - MXA902 to ANIUSB-MATRIX
 - ANIUSB-MATRIX USB output to computer with videoconferencing software
 - ANIUSB-MATRIX Dante output to MXA902 Dante input (loudspeaker)

You can also route audio manually in Designer or use Dante Controller.

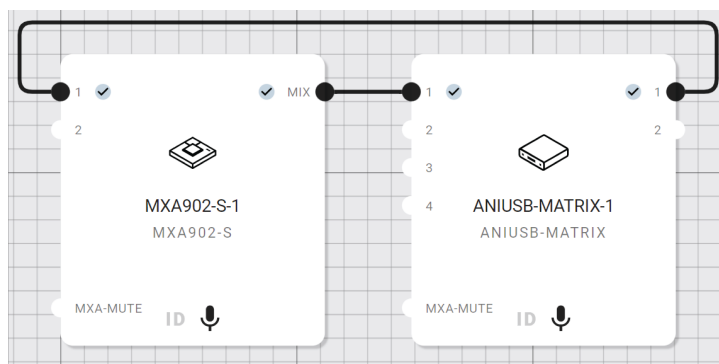

2. Check the audio routes, matrix mixer routes, and other settings to make sure they fit your needs.
3. Select Deploy and connect to send the settings to the installed devices. Designer walks you through associating the design devices with the online devices.

Step 3: Listen and Adjust

1. Open the videoconferencing software on the computer connected to the ANIUSB-MATRIX. In the settings, choose the ANIUSB-MATRIX as the speaker and microphone.
2. Place a test call with the whole system. Have the far-end caller tell you how the microphone sounds and make adjustments as needed:
 - Microphone: [Your room] > MXA902 > IntelliMix
 - Loudspeaker: [Your room] > MXA902 > Loudspeaker > Speaker output.
3. If needed, move the microphone's coverage area: [Your room] > Coverage. You can also listen to the microphone signal directly [using a Dante headphone amp](#) to help make adjustments.

MXA902 Web Application Setup Example

This example uses the MXA902's web application and Dante Controller. You might use the web application and Dante Controller if:

- You don't have many Shure devices to manage
- You need to route audio to third-party Dante devices

Regardless of what Dante devices you route to, the setup process is similar if you're working with the web application and Dante Controller. After completing this basic setup process, you should be able to:

- Open the MXA902's web application
- Route audio and adjust DSP settings
- Understand the basic workflow for working with the web application and Dante Controller

This example uses:

- Cat5e (or better) Ethernet cable
- Network switch that provides Power over Ethernet Plus (PoE+)
- [Shure Update Utility](#) and [Dante Controller](#) software

Step 1: Install and Connect

Out of the box, the MXA902 has a 20 x 20-foot (6.1 x 6.1 m) coverage area for microphone pickup and speech reproduction. You can shift the microphone coverage up to 4 feet (1.2 m) in any direction using Designer or the web application.

1. Install the microphone and connect it to a PoE+ port on the network switch using Ethernet cable.
2. Connect the computer running Shure Update Utility and Dante Controller to the same network.
3. Open Shure Update Utility. Find the MXA902 in the list of devices and double-click to open the web application.

Note: The web application uses an HTTPS connection with self-signed certificates as of firmware 6.1 and newer. You may see a warning message in your browser the first time you open the web application. To proceed, click Advanced and then select the option to trust the connection.

Step 2: Route Audio

To route audio to and from other Dante devices, use Dante Controller.

1. Open Dante Controller and find the MXA902 in the list of transmitters and receivers.
2. Find the Dante device you're sending the MXA902's microphone signal to in the list of receivers. To make an audio route, check the box where the MXA902's automix output intersects with the receiver device's input channel.
3. To route far-end audio to the MXA902's loudspeaker, check the box where the transmitter device's channel intersects with one of the MXA902's 2 Dante input channels in the receiver list. The 2 inputs are summed and sent to the loudspeaker (the summed signal is also set as the [AEC reference](#)).
4. In your videoconferencing software, make sure to select the correct microphone and loudspeaker sources.

Step 3: Listen and Adjust

1. Place a test call with the whole system. Have the far-end caller tell you how the microphone signal sounds and make adjustments in the web application as needed:
 - Microphone: MXA902 web application > IntelliMix
 - Loudspeaker: MXA902 web application > Loudspeaker > Speaker output.
 2. If needed, move the microphone's coverage area up to 4 feet (1.2 m) in any direction: MXA902 web application > Coverage. You can also listen to the microphone signal directly [using a Dante headphone amp](#) to help make adjustments.
-

MXA902 Parts

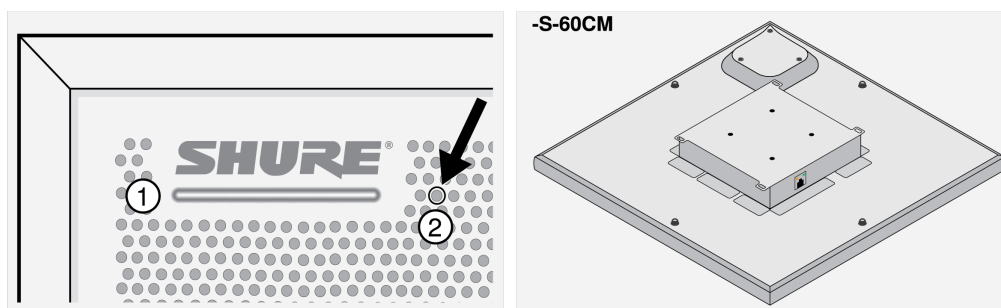
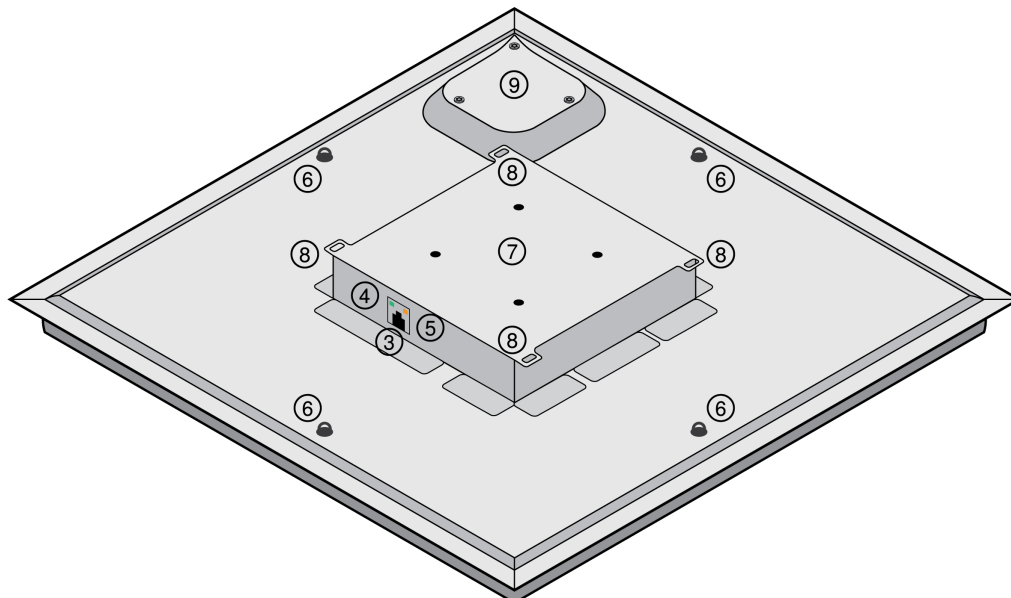

1. Mute status LED

The device mute button in Designer or the web application changes the mute status LED.

Customize LED color and behavior in Designer: Device configuration > Settings > Lights.

Mute Status LED Default Settings

Microphone Status	LED Color/Behavior
Active	Green (solid)
Muted	Red (solid)
Hardware identification	Green (flashing)
Firmware update in progress	Green (progresses along bar)
Reset	Network reset: Red (progresses along bar) Factory reset: Triggers device power-up
Error	Red (split, alternate flashing)

Microphone Status	LED Color/Behavior
Device power-up	Multi-color flash, then blue (moves quickly back and forth across bar)

Note: If LEDs are disabled, they will still turn on when the device powers up or when an error state occurs.

2. Reset button
3. RJ-45 network port
4. Network status LED (green)
 - Off = No network link
 - On = Network link established
 - Flashing = Network link active
5. Network speed LED (amber)
 - Off = 10/100 Mbps
 - On = 1 Gbps
6. Eyelet screws for suspension mounting (12 mm diameter)
7. VESA MIS-D mounting holes (100 mm spacing)
8. Safety tether attachment points
9. Loudspeaker enclosure

Power Over Ethernet Plus (PoE+)

This device requires PoE Plus (PoE+) to operate. It is compatible with **Class 4** PoE+ sources.

PoE+ is delivered in one of the following ways:

- A network switch that provides PoE+
- A PoE+ injector device (must be a gigabit device)

Note: When connected to a PoE source, the MXA902 works as a microphone but not as a loudspeaker. The red error LED also flashes. To dismiss, connect to a PoE+ source to turn on the loudspeaker or go to Settings > Lights to clear the error.

Model Variations

SKU	Description
MXA902W-S	White square microphone with loudspeaker
MXA902W-S-60CM	White square microphone with loudspeaker (60 cm)

Optional Accessories and Replacement Parts

- [A900-S-GM Gripple Mount Kit, Square](#)
- [A900-S-PM Pole Mount Kit, Square](#)
- [A900-PM-3/8IN Threaded Rod Adapter Mounting Kit](#)
- [A910-JB Junction Box Accessory](#)
- [A900-CM Ceiling Mount](#)
- [RPM904 frame and grille assembly](#)
- [RPM901W-US frame and grille assembly](#)

Note: Shure's A910-25MM accessory doesn't fit the MXA902.

What's in the Box

Square array microphone with loudspeaker	MXA902-S or MXA902-S-60CM
Hardware kit with: Cable ties (8) Strain relief tabs (3) Rubber pad set	90A49117

Reset Button

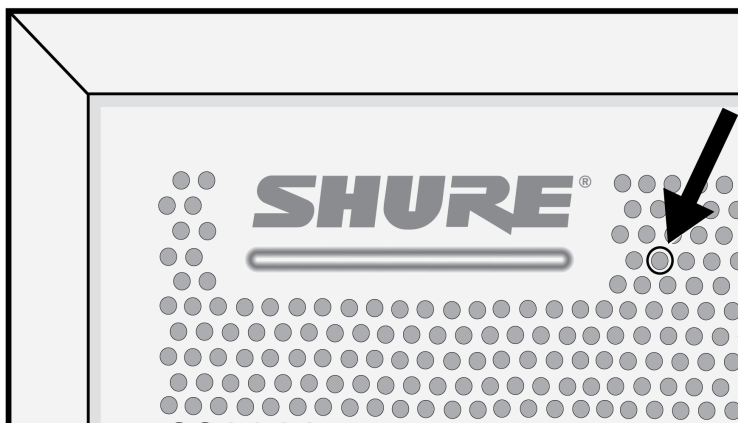

The reset button is behind the grille with a silkscreened circle around it. To push it, use a paper clip or other tool. You can also reset the device using the control software.

Reset Modes

- **Network reset** (press for 4-8 seconds): Resets all Shure control and audio network IP settings to factory defaults. Red LED along bar.
- **Full factory reset** (press for more than 8 seconds): Resets all network and configuration settings to the factory defaults. Multicolor flash, then blue LED along bar.

MXA902 Control Software

There are 2 ways to control the MXA902:

- **Option 1:** Use Shure Designer software (download at shure.com/designer)
 - Control all Shure devices in one place.
 - Route audio to and from Shure devices.
 - Use in rooms where you're connecting to other Shure devices, like mute buttons, processors, or loudspeakers.
- **Option 2:** Open the MXA902's web application with [Shure Update Utility](https://shure.com/suu) (download at shure.com/suu)
 - Control 1 device at a time.

- Route audio with [Dante Controller software](#).
- Use in rooms where you're routing audio to third-party devices.

To update firmware, use Shure Update Utility (download at shure.com/suu).

Control Devices with Shure Designer Software

To control this device's settings, use Shure Designer software. Designer enables integrators and system planners to design audio coverage for installations using MXA microphones and other Shure networked devices.

To access your device in Designer:

1. Download and install Designer on a computer connected to the same network as your device.
2. Open Designer, and check that you're connected to the correct network in File > Designer preferences.
3. Click Online devices. A list of online devices appears.
4. To identify devices, select a device and click ID in the Properties menu. Double-click the device to open the settings.

From here, you can add devices to designs or online rooms and route audio to other Shure devices. Learn more at shure.com/designer.

You can also access device settings using [Shure Web Device Discovery](#).

Note: If you're using Designer 4.7.25, refer to [MXA902 Limitations](#) for details about using the MXA902 in Designer 4.7.25 and certain Shure device firmware. Designer 6.0 doesn't have these limitations.

Use HTTPS for Web Application

This device's browser-based web application uses an HTTPS connection for confidentiality and authenticity. HTTPS encrypts most information sent between the device and the web application.

The web application uses self-signed certificates. You may see a warning message in your browser after opening the web application for the first time. To proceed, click Advanced and then select the option to trust the connection.

To control HTTPS settings, go to Settings > Services in Designer or the web application.

Available in firmware 6.1 and newer

Firmware Updates

Firmware is embedded software in each component that controls functionality. Periodically, new versions of firmware are developed to incorporate additional features and enhancements. You can install firmware using Shure Update Utility.

Download Shure Update Utility at shure.com.

MXA902 Coverage

The MXA902 uses Single-Zone Automatic Coverage technology. There is one 20 x 20-foot (6.1 x 6.1 m) coverage area that captures every talker in it with minimal configuration. The MXA902's integrated loudspeaker provides natural-sounding speech reproduction for the entire coverage area.

To access microphone coverage settings:

- **Designer:** Add the microphone to a design or room and go to [Your room] > Coverage.
- **Web application:** Go to Coverage.

Any talker in the blue coverage area has microphone coverage. Click and drag to move the coverage area up to 4 feet (1.2 m) in any direction.

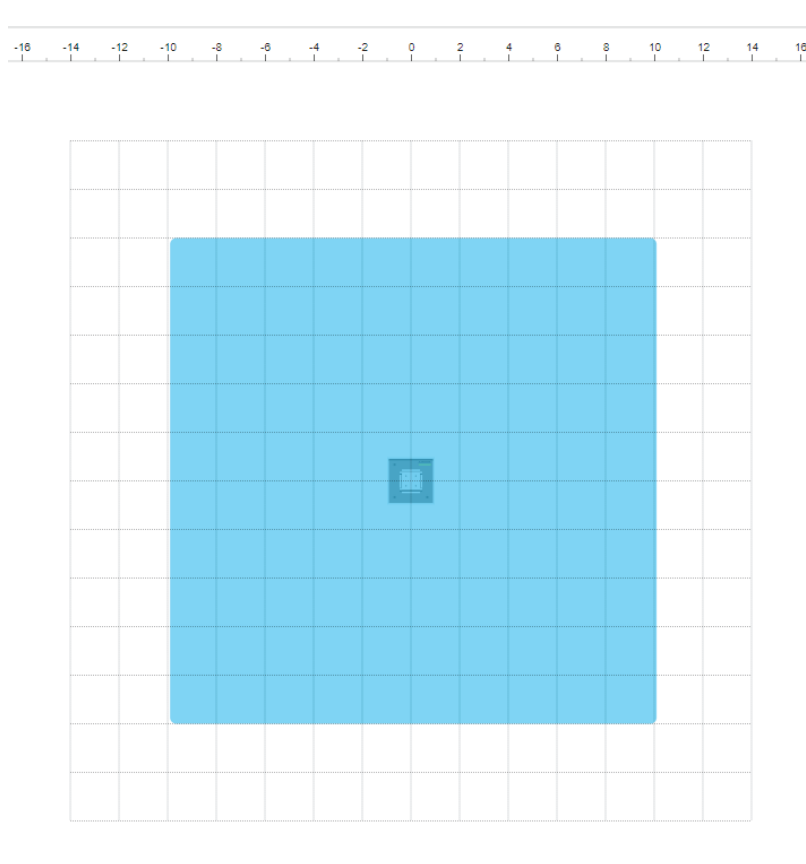

The MXA902 provides 1 automixed output with IntelliMix DSP for the far end. For most rooms, all you need to do is install the microphone above the coverage area and route the audio signal using [Shure Designer software](#) or [Dante Controller](#).

How Much Space Does the MXA902 Cover?

The MXA902's microphone coverage area is set at 20 x 20 feet (6.1 x 6.1 m). For most rooms, Shure recommends:

- Maximum distance from talker to microphone: 16 feet (4.9 m)
- Maximum mounting height: 10 feet (3 m)

The maximum distance from talker to microphone and maximum mounting height also depend on your room's acoustics, construction, and materials. Acoustically treated rooms that are less reverberant generally sound better and help improve your microphone signal.

The MXA902's loudspeaker delivers high-quality speech reproduction for the entire 20 x 20-foot (6.1 x 6.1 m) coverage area.

Note: This device does not have array height or talker height settings. Install the array and move the coverage area as needed.

Using Autofocus™ to Improve Coverage

This microphone uses built-in Autofocus technology to fine-tune microphone coverage in real time, even if meeting participants lean back or stand up. On microphones that show steerable lobes for coverage (such as the MXA710 or MXA920), you'll see the lobes moving in the coverage map as participants change positions. Autofocus only responds to in-room sound sources.

Important: Always route a reference signal to the microphone's AEC reference in channel to take full advantage of Autofocus. You should set up this reference signal even if you're using a separate DSP or direct outputs (on applicable microphones).

How to Install the MXA902

There are many ways to install the MXA902 to get great coverage in small- to medium-sized meeting rooms.

Installation Best Practices

- Don't place the microphone behind obstructions.
- Coverage depends on your room's acoustics, construction, and materials. Take these into consideration when planning.
- For most rooms, Shure recommends 10 feet (3 m) as the maximum mounting height.

Mounting options:

- [In a ceiling grid](#)
- [With a VESA mounting device](#)
- [On NPT pole](#)
- [Suspend from ceiling with A900-GM](#)
- [Suspend from ceiling with your own hardware](#)
- [On 3/8-inch threaded rod](#)
- [Attach to ceiling with A900-CM](#)

Install in a Ceiling Grid

Before you begin:

- Remove the plastic cover from the grille.
- Remove the cardboard piece between the loudspeaker and the back panel.
- If using, install the rubber pads on the corners of the microphone to prevent scratches.

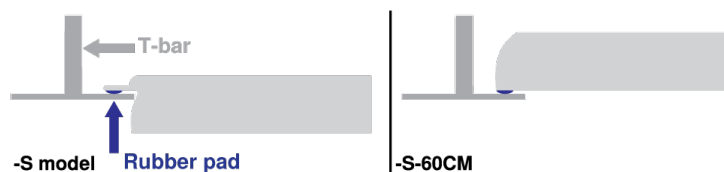

- Verify that your ceiling grid size matches your model variation.
- If using the A910-JB junction box, install it before ceiling installation.

IMPORTANT: Do not install the 60 cm model in a 2-foot (609.6 mm) ceiling grid.

1. Make space in the ceiling grid for the array microphone to be installed.
2. Route the Ethernet cable above the ceiling grid and through the opening in the ceiling.
3. Plug the Ethernet cable into the microphone.
4. Attach the safety tether between the building structure and one of the tie-off points on the back of the microphone using braided metal cable or other high-strength wire (not included). This safety measure prevents the microphone from falling in an emergency situation. Make sure there is no tension on the safety tether. Follow any local regulations.
5. Install the microphone in the ceiling grid.

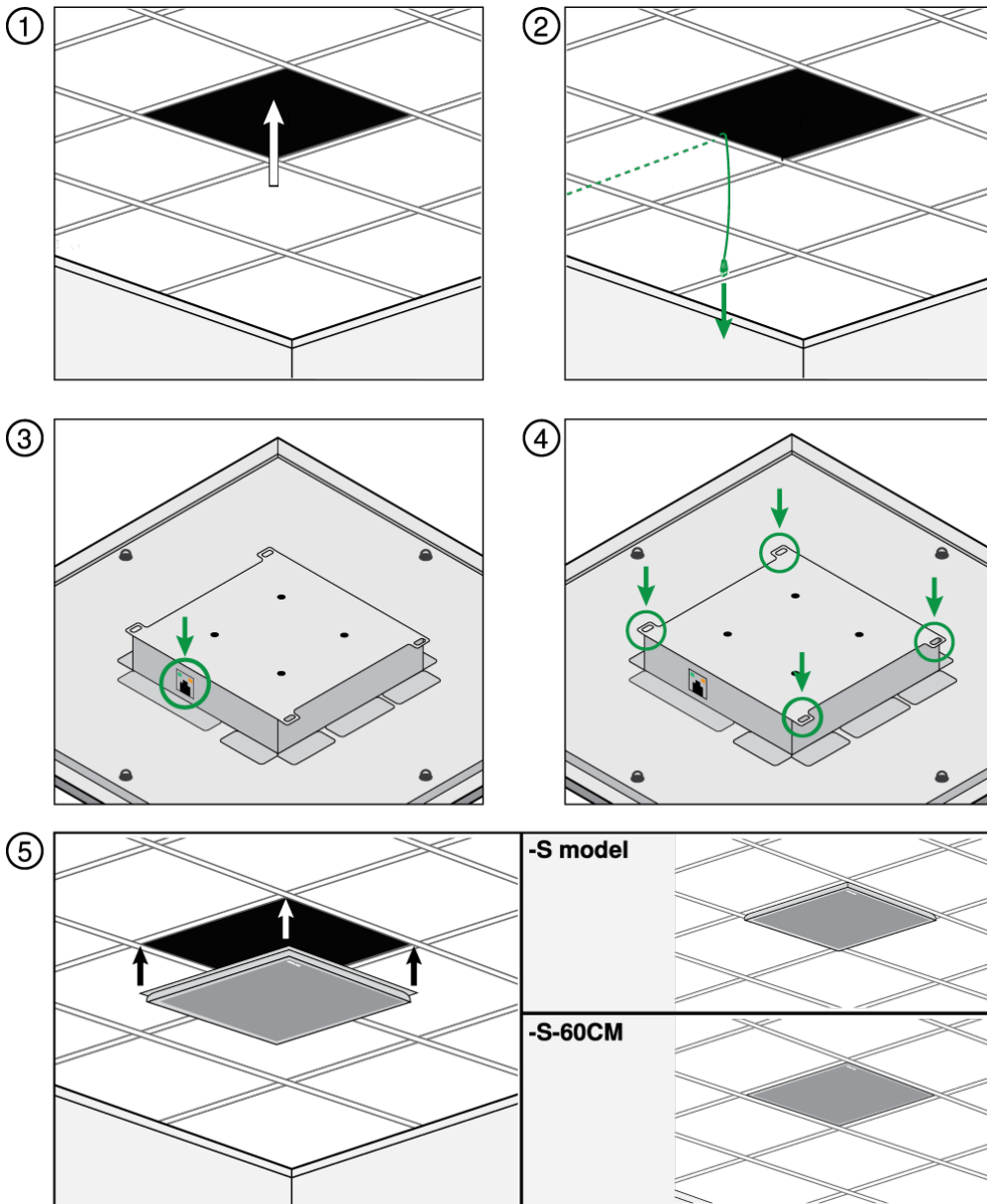

Notice



The MXA902-S-60CM is not designed or intended to be installed within a 24" ceiling grid, which is the standard grid size in North America. Mounting in such a grid in the above-shown configuration is unsafe and may cause damage to the product and/or injury to those below.

Installing the Junction Box Accessory

The A910-JB junction box mounts on square ceiling array microphones to connect conduit. There are 3 knockouts on the junction box for attaching conduit. See local regulations to determine if the junction box is necessary.

Note: Install the junction box on the microphone before installing the microphone in the ceiling.

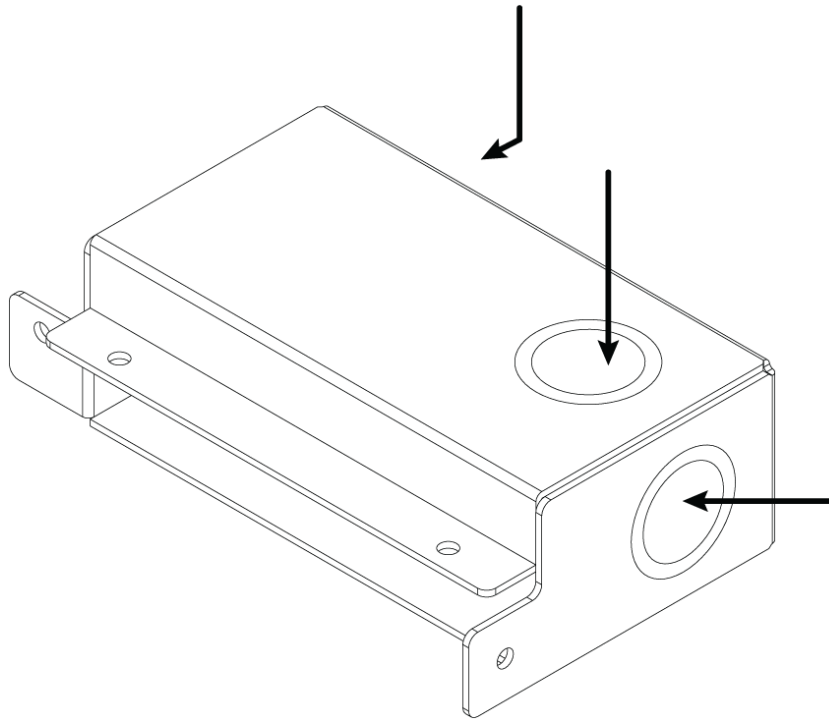

To install:

1. Remove the knockout you plan to use on the junction box.
2. Remove the 4 screws from the microphone as shown.

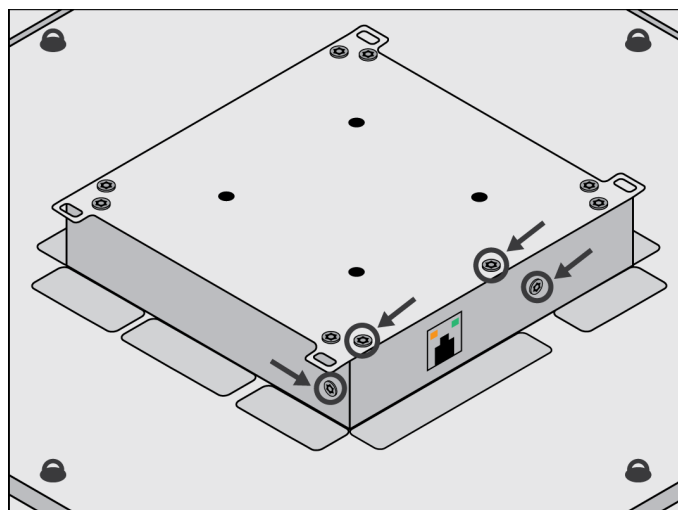

3. Align the junction box with the screw holes. If possible, plug the network cable into the microphone before securing the junction box.
4. Reinstall the 4 screws to secure the junction box to the microphone.

VESA Standardized Mounting

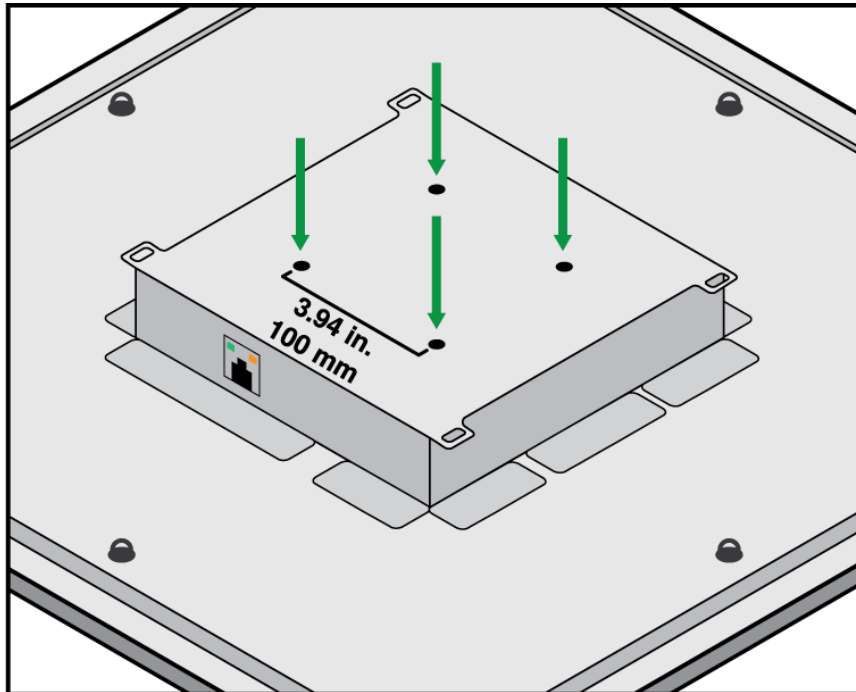

The rear plate has 4 threaded holes for attaching the microphone to a VESA mounting device. The mounting holes follow the VESA MIS-D standard:

- Screw specification: M4 thread (hole depth = 9.15 mm)
- Hole spacing: 100 mm square

The VESA mounting holes are compatible with these Shure accessories:

- [A900-PM](#)
- [A900-PM-3/8IN](#)
- [A900-CM](#)

Suspending from the Ceiling

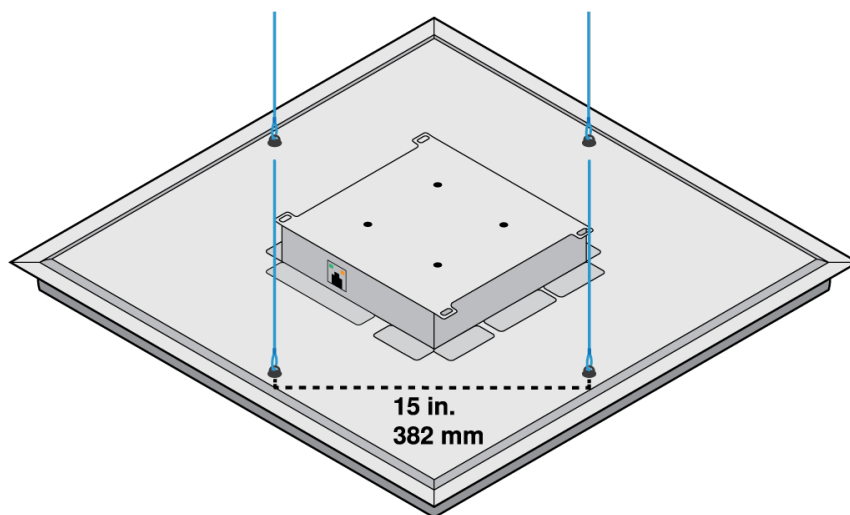

Suspend the microphone using your own equipment, or with Shure's [A900-GM kit](#) (includes mounting cables and hooks).

To mount using your own equipment, you will need:

- Braided metal cable or high-strength wire
 - Hardware to attach cable to ceiling
1. Attach the mounting cables to the 12 mm diameter eyelet screws on the microphone.
 2. Attach the cables to the ceiling using appropriate hardware.

Install on a Ceiling with the A900-CM

Attach array microphones to the ceiling with the A900-CM mounting kit.

Refer to the [A900-CM user guide](#) to learn how to install on other ceiling materials.

Adjust Microphone and Loudspeaker Levels

To adjust levels, open the MXA902 in Designer or the device web application.

Microphone Levels

To adjust, go to IntelliMix.

1. Make a test call with your videoconferencing software.
2. Talk in all parts of the coverage area at a normal speech volume and have someone on the far end listen to your signal. Adjust levels as needed. The coverage area gain fader is post-gate.
3. Adjust EQ settings as needed. You can use EQ to improve speech intelligibility and control problematic frequencies in a room (such as a low-frequency rumble caused by HVAC systems). You can also make changes to IntelliMix DSP blocks [here](#).
4. If needed, listen to the microphone signal directly [using a Dante headphone amp](#) or with [Dante Virtual Soundcard](#).

Loudspeaker Levels

To adjust, go to Loudspeaker and use the Speaker output fader.

Make a test call with your videoconferencing software and adjust the loudspeaker level as needed. If you set a higher loudspeaker level, you may need to [use a higher NLP setting on the AEC block](#) to remove echo.

If needed, use the signal generator to help with EQ adjustments. The signal generator is pre-EQ.

Mute the MXA902

The MXA902 has multiple mute points for controlling the microphone, the loudspeaker, or both:

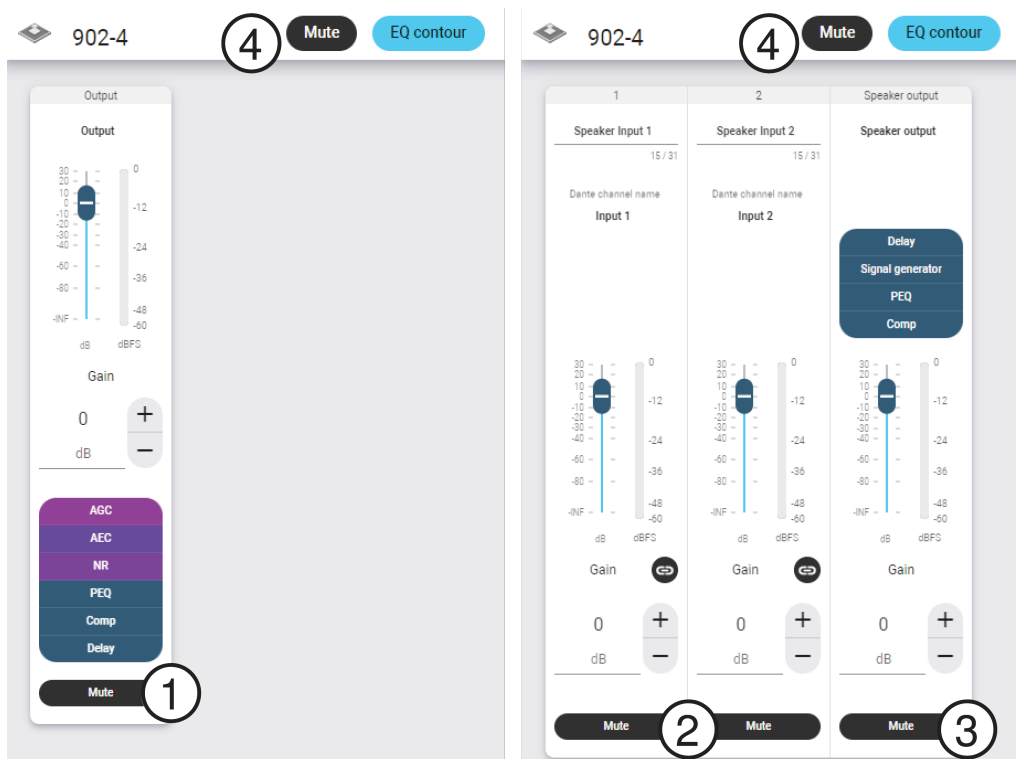

1. **IntelliMix output mute:** Mutes the microphone's Dante output channel
2. **Dante input mute:** Mutes the selected Dante input channel
3. **Speaker output mute:** Mutes the loudspeaker output
4. **Device mute:** Mutes everything (microphone and loudspeaker). This mute button also changes the mute status LED.

Use Designer's Auto Route

Designer's auto route speeds up the process of connecting systems with 1 audio processor and at least 1 microphone. Auto route also creates mute control routes in rooms with MXA network mute buttons. When you select Auto route, you can direct Designer to:

- Create audio routes and mute control routes
- Adjust audio settings
- Turn on mute synchronization
- Enable LED logic control for applicable devices

The settings are optimized for your particular combination of devices. You can adjust settings further, but auto route gives you a good starting point. Auto route works with any device in Designer.

To use auto route:

1. Place all relevant devices in a design.
2. Select Auto route. Designer optimizes microphone and DSP settings for your equipment combination.

If you remove or add devices, select Auto route again.

Note: The auto route process clears any manual routes you may have made in your design.

After auto routing a room, check and adjust settings to fit your needs. You may need to:

- Delete unnecessary routes.
- Check levels and adjust gain.
- Check that AEC reference signals are correctly routed and received in a test call.
- Fine-tune DSP blocks.
- Adjust your processor's matrix mixer routes.

If you want to auto route an online room, turn on online room editing in **File > Designer preferences**.

Note: Changes to an online room may cause audio to briefly drop out.

Refer to Designer's [Troubleshooting section](#) for help with routing.

Dante Channels

The MXA902 has:

- 2 input channels
- 1 automix output with IntelliMix DSP

The 2 input channels are summed and sent to the loudspeaker's output. These input channels are useful if you need to send a far-end signal and program audio to the loudspeaker.

The MXA902's AEC reference is the signal sent to the loudspeaker (summed signal of inputs 1 and 2).

IntelliMix DSP

This device contains IntelliMix digital signal processing blocks that can be applied to the microphone's output. The DSP blocks include:

- Acoustic echo cancellation (AEC)
- Automatic gain control (AGC)
- Noise reduction
- Compressor
- Delay

To access, go to the IntelliMix tab.

DSP Best Practices

- Apply DSP blocks as needed. Run a test of your system without DSP, and then add processing as needed to fix any issues that you hear in the audio signal.
- Unless you encounter video that lags behind audio, set delay to off.

Acoustic Echo Cancellation

In AV conferencing, a person may hear their voice echo. This happens when a near-end microphone picks up audio from the room's loudspeakers and sends it back to the far end as echo.

Acoustic echo cancellation (AEC) is a DSP algorithm that gets rid of distracting echo in your microphone signal. AEC identifies the far-end signal and stops it from being captured by the near-end microphone. During a call, AEC works constantly to optimize processing as long as far-end audio is present. AEC is necessary for clear, uninterrupted calls.

The summed signal of inputs 1 and 2 is sent to the built-in loudspeaker and is also used as the AEC reference signal.

Note: If the loudspeaker is off and you still want to use AEC, route the far-end signal you want to cancel to one of the Dante inputs.

AEC Settings

Reference Meter

Use the reference meter to visually verify the reference signal is present. The reference signal should not be clipping.

ERLE

Echo return loss enhancement (ERLE) displays the dB level of signal reduction (the amount of echo being removed). The ERLE meter generally corresponds to the reference meter.

Reference

The MXA902's reference signal is set to the built-in loudspeaker, which is the sum of the 2 Dante inputs. When the loudspeaker is on, the reference signal is post-DSP.

Non-Linear Processing

The primary component of the acoustic echo canceller is an adaptive filter. Non-linear processing supplements the adaptive filter to remove any residual echo caused by acoustic irregularities or changes in the environment. Use the lowest possible setting that is effective in your room.

Low: Use in rooms with controlled acoustics and minimal echoes. This setting provides the most natural sound for full duplex.

Medium: Use in typical rooms as a starting point. If you hear echo artifacts, try using the high setting.

High: Use to provide the strongest echo reduction in rooms with bad acoustics, or in situations where the echo path frequently changes.

Choose the Right NLP Setting

If far-end callers hear echo, test different NLP settings to find one that works. In general, it's best to use the lowest NLP setting that removes echo from your mic signal.

The level of the MXA902's loudspeaker can also affect how well the AEC removes the reference signal from the mic's signal. Experiment with using a higher NLP setting when the loudspeaker level is higher.

Noise Reduction

Noise reduction significantly reduces the amount of background noise in your signal caused by projectors, HVAC systems, or other environmental sources. It is a dynamic processor, which calculates the noise floor in the room and removes noise throughout the entire spectrum with maximum transparency.

Settings

The noise reduction setting (low, medium, or high) represents the amount of reduction in dB. Use the lowest possible setting that effectively lowers noise in the room.

Automatic Gain Control (AGC)

Automatic gain control automatically adjusts channel levels to ensure consistent volume for all talkers in all scenarios. For quieter voices, it increases gain. For louder voices, it attenuates the signal.

Enable AGC on channels where the distance between the talker and the microphone may vary, or in rooms where many different people will use the conferencing system.

Automatic gain control happens post-gate (after the automixer) and does not affect when the automixer gates on or off.

Target Level (dBFS)

Use -37 dBFS as a starting point to ensure adequate headroom and adjust if necessary. This represents the RMS (average) level, which is different from setting the input fader according to peak levels to avoid clipping.

Maximum Boost (dB)

Sets the maximum amount of gain that can be applied

Maximum Cut (dB)

Sets the maximum attenuation that can be applied

Tip: Use the boost/cut meter (not available on all microphones) to monitor the amount of gain added or subtracted from the signal. If the meter is always reaching the maximum boost or cut level, adjust the input fader so the signal is closer to the target level.

Delay

Use delay to synchronize audio and video. When a video system introduces latency (where you hear someone speak, and their mouth moves later), add delay to align audio and video.

Delay is measured in milliseconds. If there is a significant difference between audio and video, start by using larger intervals of delay time (500-1000 ms). When the audio and video are slightly out of sync, use smaller intervals to fine-tune.

Compressor

Use the compressor to control the dynamic range of the selected signal.

Threshold

When the audio signal exceeds the threshold value, the level is attenuated to prevent unwanted spikes in the output signal. The amount of attenuation is determined by the ratio value. Perform a soundcheck and set the threshold 3-6 dB above average talker levels, so the compressor only attenuates unexpected loud sounds.

Ratio

The ratio controls how much the signal is attenuated when it exceeds the threshold value. Higher ratios provide stronger attenuation. A lower ratio of 2:1 means that for every 2 dB the signal exceeds the threshold, the output signal will only exceed the threshold by 1 dB. A higher ratio of 10:1 means a loud sound that exceeds the threshold by 10 dB will only exceed the threshold by 1 dB, effectively reducing the signal by 9 dB.

Parametric Equalizer

Maximize audio quality by adjusting the frequency response with the parametric equalizer.

Common equalizer applications:

- Improve speech intelligibility
- Reduce noise from HVAC systems or video projectors
- Reduce room irregularities
- Adjust frequency response for reinforcement systems

Setting Filter Parameters

Adjust filter settings by manipulating the icons in the frequency response graph, or by entering numeric values. Disable a filter using the checkbox next to the filter.

PEQ Filter Settings

Setting	Function
Filter Type	<p>Only the first and last band have selectable filter types.</p> <p>Parametric: Attenuates or boosts the signal within a customizable frequency range</p> <p>Low Cut: Rolls off the audio signal below the selected frequency</p> <p>Low Shelf: Attenuates or boosts the audio signal below the selected frequency</p> <p>High Cut: Rolls off the audio signal above the selected frequency</p> <p>High Shelf: Attenuates or boosts the audio signal above the selected frequency</p>
Frequency	Select the center frequency of the filter to cut or boost
Gain	Adjusts the level for a specific filter (+/- 18 dB)
Q	Adjusts the range of frequencies affected by the filter. As this value increases, the bandwidth becomes thinner.
Width	<p>Adjusts the range of frequencies affected by the filter. The value is represented in octaves.</p> <p>Note: The Q and width parameters affect the equalization curve in the same way. The only difference is the way the values are represented.</p>

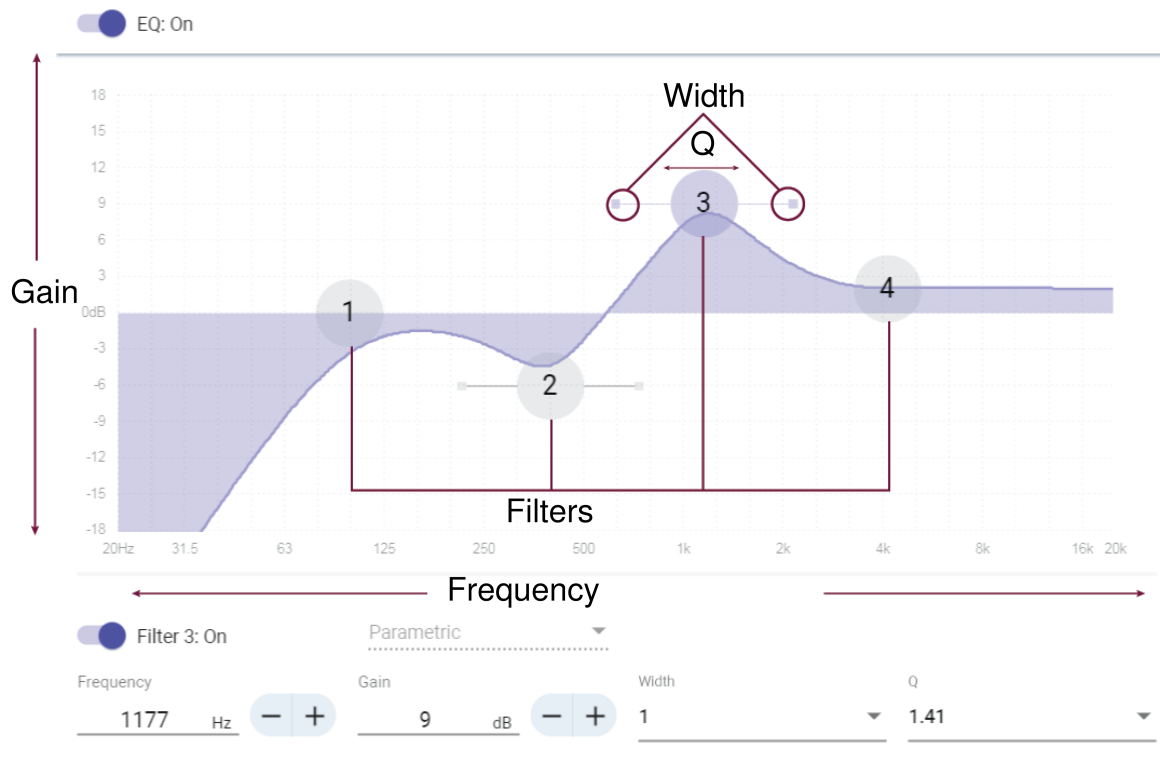

Copy and Paste Equalizer Channel Settings

Use to quickly apply the same PEQ setting across multiple channels.

1. Select the PEQ of the desired channel.
2. Click copy.
3. Select the channel to apply the PEQ setting to and click paste.

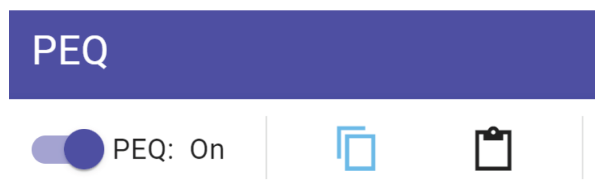

Equalizer Applications

Conferencing room acoustics vary based on room size, shape, and construction materials. Use the guidelines in following table.

Uses for EQ

EQ Application	Suggested Settings
Treble boost for improved speech intelligibility	Add a high shelf filter to boost frequencies greater than 1 kHz by 3-6 dB
HVAC noise reduction	Add a low cut filter to attenuate frequencies below 200 Hz

EQ Application	Suggested Settings
<p>Reduce flutter echoes and sibilance</p>	<p>Identify the specific frequency range that "excites" the room:</p> <ol style="list-style-type: none"> 1. Set a narrow Q value. 2. Increase the gain to between +10 and +15 dB, and then experiment with frequencies between 1 kHz and 6 kHz to pinpoint the range of flutter echoes or sibilance. 3. Reduce the gain at the identified frequency (start between -3 and -6 dB) to minimize the unwanted room sound.
<p>Reduce hollow, resonant room sound</p>	<p>Identify the specific frequency range that "excites" the room:</p> <ol style="list-style-type: none"> 1. Set a narrow Q value. 2. Increase the gain to between +10 and +15 dB, and then experiment with frequencies between 300 Hz and 900 Hz to pinpoint the resonant frequency. 3. Reduce the gain at the identified frequency (start between -3 and -6 dB) to minimize the unwanted room sound.

EQ Contour

Use the EQ contour to quickly apply a high-pass filter at 150 Hz to the microphone's signal.

Select EQ contour to turn it on or off.

Encryption

Audio is encrypted with the Advanced Encryption Standard (AES-256), as specified by the US Government National Institute of Standards and Technology (NIST) publication FIPS-197. Shure devices that support encryption require a password to make a connection. Encryption is not supported with third-party devices.

In Designer, you can turn on encryption for all devices in a room: [Your room] > Settings > Audio encryption.

To activate encryption in the web application, go to Settings > Audio encryption > Enable encryption.

Important: For encryption to work:

- All Shure devices on your network must use encryption.
- Disable AES67 in Dante Controller. AES67 and AES-256 cannot be used at the same time.

Set Up the 802.1X Protocol for a Device

Select Shure devices support the IEEE 802.1X port access protocol for network authentication.

Important: To use the 802.1X security protocol with Shure devices, set the network switch to multiple host authentication. You must also make accommodations to allow the audio NIC to connect to the network. The audio NIC doesn't support the 802.1X protocol.

Setting up 802.1X is a two-part process.

To set up 802.1X, you will need:

- Details about your authentication server's EAP method
- Any required credentials or certificates for that method, for example:
 - MD5 and PWD
 1. User ID and passphrase
 - TLS and PEAP
 1. User ID and passphrase
 2. Certificate (with certificate types) in the .PEM format
- Any passwords to access the devices if they are password locked

Step 1: Configure Settings on Test Network

1. Connect the device to your test network and discover it using Designer.
2. Set a device password if desired.
3. Double-click the device and go to **Settings > Network > 802.1X**.
4. Choose your EAP method from the menu.
5. Enter any required credentials and load any necessary certificates.
6. Press **Save** to save the 802.1X settings to the device.
7. Enable 802.1X and select **Reboot later**.

Step 2: Connect to a Credentialed Network

1. Connect your device to the credentialed network.
2. Ensure that Designer is connected to the credentialed network.
3. Go to **Settings > Network > 802.1X** and enable 802.1X. Reboot the device for the 802.1X settings to take effect.
4. If the device doesn't appear in Designer after the reboot, reconnect to the test network and check all 802.1X settings for the selected EAP method.

Turn Off or Clear 802.1X Settings

You can turn off 802.1X settings temporarily, or clear them from the device. Open the device and go to **Settings > Network > 802.1X**

- **Disable:** Click the 802.1X switch to turn off 802.1X settings. Click the switch again to enable 802.1X.
- **Clear:** Click **Clear 802.1X settings** to remove 802.1X settings from the device.

Note: Resetting to factory default clears all 802.1X settings.

Change 802.1X Settings

You may need to change a device's 802.1X settings if the enterprise's 802.1X settings are changing. The best way to do this is to change the 802.1X settings on the devices, and then make changes to the authentication server.

To change device settings:

1. While still connected to the credentialed network, find the device in Designer and go to **Settings > Network > 802.1X**.
2. Make changes and click **Save**.
3. Make any changes to the authentication server.
4. Reboot your devices. The devices should connect to the credentialed network with the updated 802.1X settings.

Troubleshooting 802.1X Setup Issues

If the device doesn't appear in Designer on the credentialed network, there's a problem with the device's 802.1X settings. To troubleshoot, take the device off the credentialed network and connect it to the test network. You can make any necessary changes to the 802.1X settings, and then reconnect to the credentialed network.

If you attempt to enable 802.1X on a device, but the authentication fails, you will see this notification:

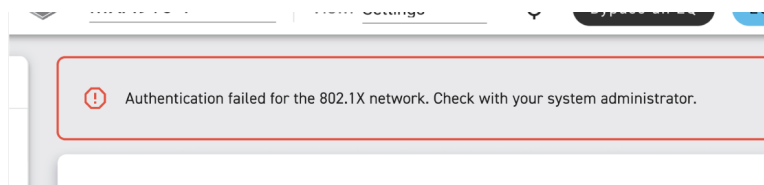

If this occurs, check with your system administrator.

Networking Best Practices

When connecting Shure devices to a network, use the following best practices:

- Always use a "star" network topology by connecting each device directly to the switch or router.
- Connect all Shure networked devices to the **same network** and set to the **same subnet**.
- Allow all Shure software through the firewall on your computer.
- Use only 1 DHCP server per network. Disable DHCP addressing on additional servers.
- Power on the switch and DHCP server before powering on the Shure devices.
- To expand the network, use multiple switches in a star topology.
- All devices must be at the same firmware revision level.

Switch and Cable Recommendations for Dante Networking

Switches and cables determine how well your audio network performs. Use high-quality switches and cables to make your audio network more reliable.

Network switches should have:

- Gigabit ports. 10/100 switches may work on small networks, but gigabit switches perform better.
- Power over Ethernet (PoE) or PoE+ ports for any devices that require power
- Management features to provide information about port speed, error counters, and bandwidth used
- Ability to switch off Energy Efficient Ethernet (EEE). EEE (also known as "Green Ethernet") may cause audio dropouts and problems with clock synchronization.
- Diffserv (DSCP) Quality of Service (QoS) with strict priority and 4 queues

Ethernet cables should be:

- Cat5e or better
- Shielded

For more information, [see our FAQ](#) about switches to avoid.

Device IP Configuration

This Shure device uses 2 IP addresses: one for Shure control, and one for Dante audio and control. For most installations, the Shure control and Dante audio IP addresses should be in the same subnet range.

- **Shure control**
 - Carries data for Shure control software, firmware updates, and third-party control systems (such as AMX or Crestron)
- **Dante audio and control**
 - Carries Dante digital audio and control data for Dante Controller
 - Requires a wired, gigabit Ethernet connection to operate

To access these settings in Designer, go to [Your device] > Settings > IP configuration.

Note: [Refer to our FAQ](#) if you're using Shure profiles on NETGEAR M4250-series switches.

Setting Latency

Latency is the amount of time for a signal to travel across the system to the outputs of a device. To account for variances in latency time between devices and channels, Dante has a predetermined selection of latency settings. When the same setting is selected, it ensures that all Dante devices on the network are in sync.

These latency values should be used as a starting point. To determine the exact latency to use for your setup, deploy the set-up, send Dante audio between your devices, and measure the actual latency in your system using Audinate's Dante Controller software. Then round up to the nearest latency setting available, and use that one.

Use Audinate's Dante Controller software to change latency settings.

Latency Recommendations

Latency Setting	Maximum Number of Switches
0.25 ms	3
0.5 ms (default)	5
1 ms	10
2 ms	10+

QoS (Quality of Service) Settings

QoS settings assign priorities to specific data packets on the network, ensuring reliable audio delivery on larger networks with heavy traffic. This feature is available on most managed network switches. Although not required, assigning QoS settings is recommended.

Note: Coordinate changes with the network administrator to avoid disrupting service.

To assign QoS values, open the switch interface and use the following table to assign Dante[®]-associated queue values.

- Assign the highest possible value (shown as 4 in this example) for time-critical PTP events
- Use descending priority values for each remaining packet.

Dante QoS Priority Values

Priority	Usage	DSCP Label	Hex	Decimal	Binary
High (4)	Time-critical PTP events	CS7	0x38	56	111000

Priority	Usage	DSCP Label	Hex	Decimal	Binary
Medium (3)	Audio, PTP	EF	0x2E	46	101110
Low (2)	(reserved)	CS1	0x08	8	001000
None (1)	Other traffic	BestEffort	0x00	0	000000

Note: Switch management may vary by manufacturer and switch type. Consult the manufacturer's product guide for specific configuration details.

For more information on Dante requirements and networking, visit www.audinate.com.

Networking Terminology

PTP (Precision Time Protocol): Used to synchronize clocks on the network

DSCP (Differentiated Services Code Point): Standardized identification method for data used in layer 3 QoS prioritization

IP Ports and Protocols

This list may change with new firmware releases. Current IP ports and protocols:

Shure Control

Port	TCP/UDP	Protocol	Description	Factory Default
21	TCP	FTP	Required for firmware updates (otherwise closed)	Closed
22	TCP	SSH	Secure Shell Interface	Closed
23	TCP	Telnet	Not supported	Closed
53	UDP	DNS	Domain Name System	Closed
67	UDP	DHCP	Dynamic Host Configuration Protocol	Open
68	UDP	DHCP	Dynamic Host Configuration Protocol	Open
80*	TCP	HTTP	Required to launch embedded web server	Open
443**	TCP	HTTPS	HTTPS/device API/camera tracking	Closed
2202	TCP	ASCII	Required for 3rd party control strings	Open
5353	UDP	mDNS [†]	Required for device discovery	Open
57383	UDP	SDT (unicast)	Required for inter-device communication	Open
8023	TCP	Telnet	Debug console interface	Closed
8180	TCP	HTML	Required for web application (legacy firmware only)	Open
8427	UDP	SLP [†]	Required for inter-device communication	Open
64000	TCP	Telnet	Required for Shure firmware update	Open

*These ports must be open on the PC or control system to access the device through a firewall.

**Some firmware supports HTTPS. HTTPS isn't available for all devices.

†These protocols require multicast. Ensure multicast has been correctly configured for your network.

[Refer to Audinate's website](#) for information about ports and protocols used by Dante audio.

Digital Audio Networking

Dante® digital audio is carried over standard Ethernet and operates using standard internet protocols. Dante provides low latency, tight clock synchronization, and high Quality-of-Service (QoS) to provide reliable audio transport to a variety of Dante devices. Dante audio can coexist safely on the same network as IT and control data, or can be configured to use a dedicated network.

Compatibility with Dante Domain Manager

This device is compatible with Dante Domain Manager software (DDM). DDM is network management software with user authentication, role-based security, and auditing features for Dante networks and Dante-enabled products.

Considerations for Shure devices controlled by DDM:

- When you add Shure devices to a Dante domain, set the local controller access to Read Write. Otherwise, you won't be able to access Dante settings, perform a factory reset, or update device firmware.
- If the device and DDM can't communicate over the network for any reason, you won't be able to control Dante settings, perform a factory reset, or update device firmware. When the connection is reestablished, the device follows the policy set for it in the Dante domain.
- If Dante device lock is on, DDM is offline, or the configuration of the device is set to Prevent, some device settings are disabled. These include: Dante encryption, MXW association, AD4 Dante browse and Dante cue, and SCM820 linking.

Refer to [Dante Domain Manager's documentation](#) for more information.

Dante Flows for Shure Devices

Dante flows get created any time you route audio from one Dante device to another. One Dante flow can contain up to 4 audio channels. For example: sending all 5 available channels from an MXA310 to another device uses 2 Dante flows, because 1 flow can contain up to 4 channels.

Every Dante device has a specific number of transmit flows and receive flows. The number of flows is determined by Dante platform capabilities.

Dante Flows for Shure Devices

Dante Platform	Shure Devices Using Platform	Transmit Flow Limit	Receive Flow Limit
Brooklyn II	ULX-D, SCM820, MXWAPT, MXWANI, P300, MXCWAPT	32	32
Brooklyn II (without SRAM)	MXA920, MXA910, MXA902, MXA710, AD4, AD600, APXD2	16	16
IP Core	MXA920-V3, MXA902-V3, MXA901	32	32

Dante Platform	Shure Devices Using Platform	Transmit Flow Limit	Receive Flow Limit
Ultimo/UltimoX	MXA310, ANI4IN, ANI4OUT, ANIUSB-MATRIX, ANI22, MXN5-C	2	2
DEP	ANIUSB-MATRIX-V3	2	2
DAL	IntelliMix Room	16	16

[Learn more about Dante flows in our FAQs](#) or from [Audinate](#).

AES67

AES67 is a networked audio standard that enables communication between hardware components which use different IP audio technologies. This Shure device supports AES67 for increased compatibility within networked systems for live sound, integrated installations, and broadcast applications.

The following information is critical when transmitting or receiving AES67 signals:

- Update Dante Controller software to the newest available version to ensure the AES67 configuration tab appears.
- Before turning encryption on or off, you must disable AES67 in Dante Controller.
- AES67 cannot operate when the transmit and receive devices both support Dante.

Shure Device Supports:	Device 2 Supports:	AES67 Compatibility
Dante and AES67	Dante and AES67	No. Must use Dante.
Dante and AES67	AES67 without Dante. Any other audio networking protocol is acceptable.	Yes

Separate Dante and AES67 flows can operate simultaneously. The total number of flows is determined by the maximum flow limit of the device.

Sending Audio from a Shure Device

All AES67 configuration is managed in Dante Controller software. For more information, refer to the Dante Controller user guide.

1. Open the Shure transmitting device in Dante Controller.
2. Enable AES67.
3. Reboot the Shure device.
4. Create AES67 flows according to the instructions in the [Dante Controller user guide](#).

Receiving Audio from a Device Using a Different Audio Network Protocol

Third-party devices: When the hardware supports SAP, flows are identified in the routing software that the device uses. Otherwise, to receive an AES67 flow, the AES67 session ID and IP address are required.

Shure devices: The transmitting device must support SAP. In Dante Controller, a transmit device (appears as an IP address) can be routed like any other Dante device.

Paint Square Array Microphones

You can paint the grille and frame of square ceiling array microphones to blend in with a room's design.

Note: Don't remove any of the screws on the MXA902's loudspeaker enclosure while painting.

Step 1: Remove the Frame and Grille

1. On each side of the frame, remove the 6 screws and washers that attach the main assembly to the frame.

Important: Do not remove the 4 recessed screws in each corner.

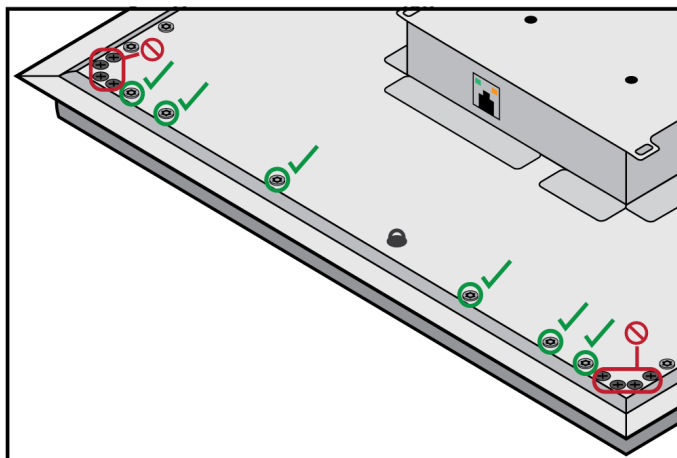

2. Carefully lift the assembly out of the frame.
3. Remove the gray plastic LED lightpipe. Leave the black plastic guide in place.
4. Remove all 4 recessed screws from one side of the frame. Remove that side of the frame.

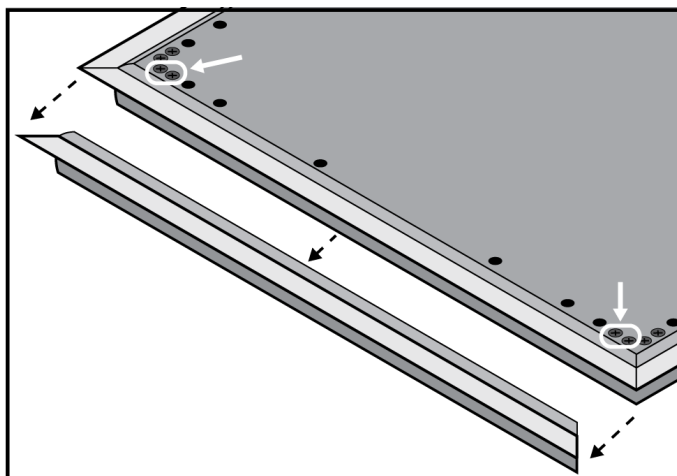

5. Slide the flat grille out of the frame.
6. Carefully remove the foam piece from the grille. Pull from the edges, where it is attached with hook-and-loop fastener strips.

Important: Do not paint the foam.

7. Before painting, reinstall the side of the frame you removed in step 1.4.

Step 2: Mask and Paint

1. Use masking tape to cover the entire extrusion (highlighted in black) that runs along the inside of the frame. This ensures that the necessary metal pieces make contact when reassembled.

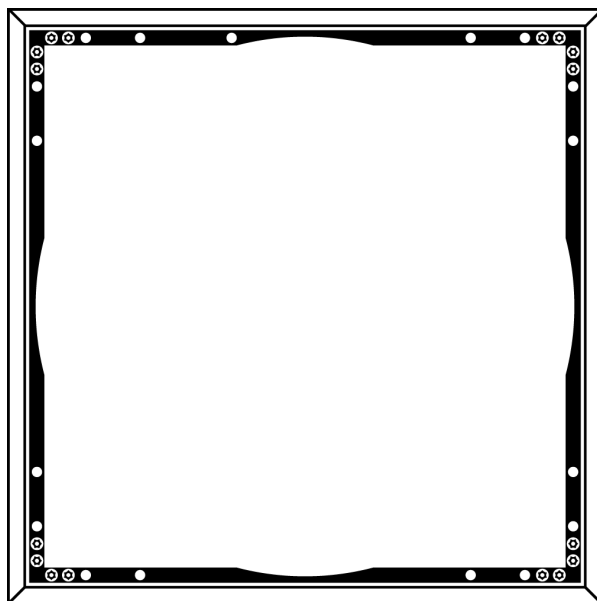

2. Use masking tape to cover the hook-and-loop fastener strips on the grille.
3. Paint the frame and grille. Let them dry completely before reassembling. Do not paint any part of the main assembly.

Step 3: Reassembly

1. Attach the foam piece to the grille with the hook-and-loop fastener strips.
2. Remove one side of the frame as in step 1.4. Slide the grille back into the frame.
3. Attach the remaining side of the frame and secure it with the 4 screws.
4. Attach the LED lightpipe to the black plastic guide piece.
5. Align the LED with the lightpipe and put the main assembly back in place on the frame.

Note: The label on the assembly is in the corner that corresponds to the LED.

6. Install 6 screws per side to secure the main assembly to the frame. Do not over-tighten.

Use Command Strings

This device receives logic commands over the network. Many parameters controlled through Designer can be controlled using a third-party control system, using the appropriate command string.

Common applications:

- Mute
- LED color and behavior
- Loading presets
- Adjusting levels

A complete list of command strings is available at:

pubs.shure.com/command-strings/mxa902.

Troubleshooting

MXA902 Troubleshooting

Problem	Solution
No microphone signal or signal is quiet/distorted	<p>Check cables.</p> <p>Verify that output channel isn't muted.</p> <p>Check that output levels are not set too low.</p>
No loudspeaker signal	<p>Check that MXA902 is plugged in to a PoE+ source. The MXA902 powers on when connected to PoE, but the loudspeaker does not work.</p> <p>Check cables.</p> <p>Verify that input channels aren't muted.</p> <p>Check that signals are properly routed to the input channels.</p>
Microphone sound quality is muffled or hollow	<p>Check that coverage area is positioned correctly and mic levels are sufficient.</p> <p>Use EQ to adjust frequency response.</p>
MXA902 does not power on	<p>Check that MXA902 is plugged in to a PoE+ source. The MXA902 powers on when connected to PoE, but the loudspeaker does not work.</p> <p>Check network cables and connections.</p>
MXA902 doesn't show up in Designer	<p>Ensure that MXA902 has power.</p> <p>Make sure MXA902 is on the same network and subnet as PC.</p> <p>Turn off network interfaces not used to connect to the device (such as Wi-Fi).</p> <p>Check that DHCP server is functioning (if applicable).</p> <p>Reset the device if necessary.</p> <p>Refer to no online devices FAQ for more help.</p>
MXA902 doesn't show up in Shure Web Device Discovery	<p>Ensure that MXA902 has power.</p> <p>Check that Shure Web Device Discovery is updated.</p> <p>Make sure MXA902 is on the same network as PC.</p> <p>Check that DHCP server is functioning (if applicable).</p> <p>Reset the device if necessary.</p> <p>Refer to the devices don't appear FAQ for more help.</p>

Problem	Solution
Flashing red error LED	In the web application, go to Settings > General > Export log to export the device event log. Use the event logs to get more information and contact Shure if necessary.
No lights	Go to [Your device] > Settings > Lights. Check if brightness is disabled or if any other settings are turned off. If the device is in a room using Designer's call status feature , mute status LEDs are off when not in a call.
Web application lags in Google Chrome browser	Turn off hardware acceleration option in Chrome.

Additional Resources

- [Shure Knowledge Base FAQs](#)
- [Command strings for Shure devices](#)
- [Shure API documentation](#)
- [Shure Enterprise Networking Troubleshooting Checklist](#)
- [Training from the Shure Audio Institute](#)
- [Shure Systems YouTube channel](#)

Download Shure Software

- [Shure Designer](#)
- [Shure Update Utility](#)
- [Shure Web Device Discovery](#)
- [Software and firmware archive](#)

Specifications

General

Coverage Area Size

20 x 20 ft (6.1 x 6.1 m)

Coverage Type

Single-zone automatic

Power Requirements

Power over Ethernet Plus (PoE+), Class 4

Power Consumption

24 W maximum

Control Software

Designer

Cable Requirements

Cat5e or higher (shielded cable recommended)

Connector Type

RJ45

Plenum Rating

UL2043 (Suitable for Air Handling Spaces)

Dust Protection

IEC 60529 IP5X Dust Protected

Operating Temperature Range

-6.7°C (20°F) to 40°C (104°F)

Storage Temperature Range

-29°C (-20°F) to 74°C (165°F)

Microphone

Microphone Elements

113 MEMS

Frequency Response

125 Hz to 20 kHz

AES67 or Dante Digital Output

Channel Count	1 output channel
Sampling Rate	48 kHz
Bit Depth	24

Sensitivity

at 1 kHz

-1.74 dBFS/Pa

Maximum SPL

Relative to 0 dBFS overload

95.74 dB SPL

Signal-to-Noise Ratio

Ref. 94 dB SPL at 1 kHz

75.76 dB A-weighted

Latency

Does not include Dante latency

26.6 ms

Self Noise

18.24 dB SPL-A

Dynamic Range

77.5 dB

Digital Signal Processing

Automatic mixing, acoustic echo cancellation (AEC), noise reduction, automatic gain control, compressor, delay, equalizer (4-band parametric), mute, gain (140 dB range)

Acoustic Echo Cancellation Tail Length

Up to 250 ms

Loudspeaker

AES67 or Dante Digital Input

Channel Count	2 input channels
----------------------	------------------

Frequency Range (-10 dB)

120 Hz to 20 kHz

Maximum Output Level

At 1 meter

Pink noise	86 dB SPL
1 kHz sine tone	88 dB SPL

Coverage Angle

Average of 1 octave band centered on 4 kHz

80°

Digital Signal Processing

Delay, compressor, signal generator, equalizer (4-band parametric)

Latency

Not including Dante latency

6.3 ms

MXA902 Microphone Frequency Response

Frequency response measured directly on-axis from a distance of 6 feet (1.83 m).

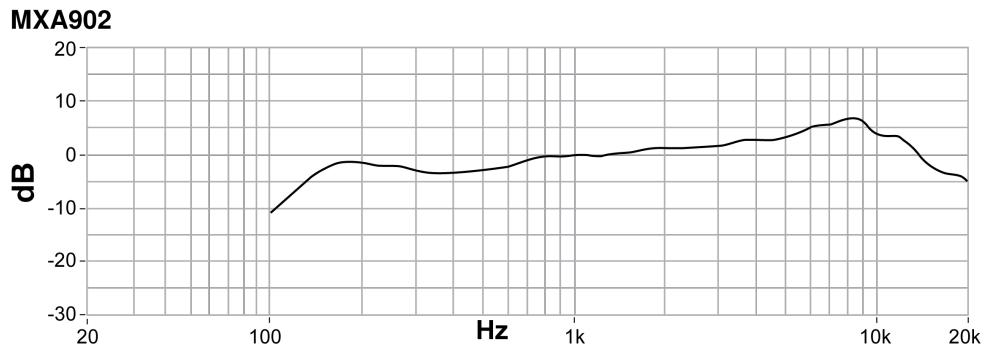

Dimensions

MXA902-S:



- A (Flange): 0.41 in. (10.5 mm)
- B (Edge to edge): 23.77 in. (603.8 mm)
- C (Height): 2.2 in. (56.04 mm)

MXA902-S-60CM:

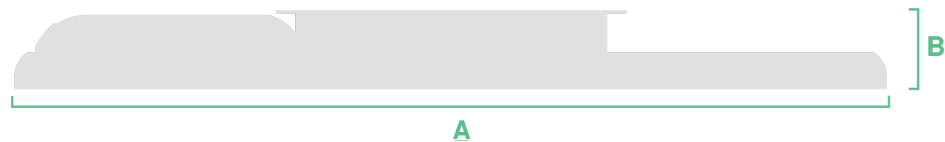

- A (Edge to edge): 23.38 in. (593.8 mm)
- B (Height): 2.2 in. (56.04 mm)

Weight

- MXA902-S or MXA902-S-60CM: 12.7 lb. (5.8 kg)

IMPORTANT SAFETY INSTRUCTIONS

1. READ these instructions.
2. KEEP these instructions.
3. HEED all warnings.
4. FOLLOW all instructions.
5. DO NOT use this apparatus near water.
6. CLEAN ONLY with dry cloth.

7. DO NOT block any ventilation openings. Allow sufficient distances for adequate ventilation and install in accordance with the manufacturer's instructions.
8. DO NOT install near any heat sources such as open flames, radiators, heat registers, stoves, or other apparatus (including amplifiers) that produce heat. Do not place any open flame sources on the product.
9. DO NOT defeat the safety purpose of the polarized or grounding type plug. A polarized plug has two blades with one wider than the other. A grounding type plug has two blades and a third grounding prong. The wider blade or the third prong are provided for your safety. If the provided plug does not fit into your outlet, consult an electrician for replacement of the obsolete outlet.
10. PROTECT the power cord from being walked on or pinched, particularly at plugs, convenience receptacles, and the point where they exit from the apparatus.
11. ONLY USE attachments/accessories specified by the manufacturer.
12. USE only with a cart, stand, tripod, bracket, or table specified by the manufacturer, or sold with the apparatus. When a cart is used, use caution when moving the cart/apparatus combination to avoid injury from tip-over.



13. UNPLUG this apparatus during lightning storms or when unused for long periods of time.
14. REFER all servicing to qualified service personnel. Servicing is required when the apparatus has been damaged in any way, such as power supply cord or plug is damaged, liquid has been spilled or objects have fallen into the apparatus, the apparatus has been exposed to rain or moisture, does not operate normally, or has been dropped.
15. DO NOT expose the apparatus to dripping and splashing. DO NOT put objects filled with liquids, such as vases, on the apparatus.
16. The MAINS plug or an appliance coupler shall remain readily operable.
17. The airborne noise of the Apparatus does not exceed 70dB (A).
18. Apparatus with CLASS I construction shall be connected to a MAINS socket outlet with a protective earthing connection.
19. To reduce the risk of fire or electric shock, do not expose this apparatus to rain or moisture.
20. Do not attempt to modify this product. Doing so could result in personal injury and/or product failure.
21. Operate this product within its specified operating temperature range.

	This symbol indicates that dangerous voltage constituting a risk of electric shock is present within this unit.
	This symbol indicates that there are important operating and maintenance instructions in the literature accompanying this unit.

Important Product Information

The equipment is intended to be used in professional audio applications.

Please follow your regional recycling scheme for batteries, packaging, and electronic waste.

Waste Electrical and Electronic Equipment (WEEE) Directive



In the European Union and the United Kingdom, this label indicates that this product should not be disposed of with household waste. It should be deposited at an appropriate facility to enable recovery and recycling.

Registration, Evaluation, Authorization of Chemicals (REACH) Directive

REACH (Registration, Evaluation, Authorization of Chemicals) is the European Union (EU) and the United Kingdom (UK) chemical substances regulatory framework. Information on substances of very high concern contained in Shure products in a concentration above 0.1% weight over weight (w/w) is available upon request.

Dante is a registered trademark of Audinate Pty Ltd.

Information to the user

This product has been tested and found to comply with the limits for a Class A digital device pursuant to Part 15 of the FCC Rules. These limits are designed to provide reasonable protection against harmful interference when the equipment is operated in a commercial environment. This product generates, uses, and can radiate radio frequency energy and, if not installed and used in accordance with the manufacturer's instruction manual, may cause harmful interference with radio communications. Operation of this product in a residential area is likely to cause harmful interference, in which case you will be required to correct the interference at your own expense.

This device complies with Part 15 of the FCC Rules. Operation is subject to the following two conditions:

1. This device may not cause harmful interference.
2. This device must accept any interference received, including interference that may cause undesired operation.

Notice: The FCC regulations provide that changes or modifications not expressly approved by Shure Incorporated could void your authority to operate this equipment.

These limits are designed to provide reasonable protection against harmful interference in a non-residential installation. However, there is no guarantee that interference will not occur in a particular installation. If this equipment does cause harmful interference with radio or television reception, which can be determined by turning the equipment off and on, you are encouraged to try to correct the interference by one or more of the following measures:

- Reorient or relocate the antenna of the radio/television receiver.
- Increase the separation between this equipment and the radio/television receiver.
- Plug the equipment into a different outlet so that the equipment and the radio/television receiver are on different power mains branch circuits.
- Consult a representative of Shure or an experienced radio/television technician for additional suggestions.

EMC conformance testing is based on the use of supplied and recommended cable types. The use of other cable types may degrade EMC performance.

Shure has determined that this product is a Class A harmonized product. The following sections provide country-specific EMC/EMI or product safety information.

For information regarding responsible party and other matters relating to FCC compliance, please contact Shure Incorporated, 5800 W. Touhy Avenue, Niles, Illinois 60714-4608 U.S.A. [shure.com/contact](https://www.shure.com/contact)

EU Class A Warning

This is a Class A product. In a domestic environment this product may cause radio interference in which case the user may be required to take adequate measures.

Certifications

CE Notice

Hereby, Shure Incorporated declares that this product with CE Marking has been determined to be in compliance with European Union requirements.

The full text of the EU declaration of conformity is available at the following site: <https://www.shure.com/en-EU/support/declarations-of-conformity>.

UKCA Notice

Hereby, Shure Incorporated declares that this product with UKCA Marking has been determined to be in compliance with UK-CA requirements.

The full text of the UK declaration of conformity is available at the following site: <https://www.shure.com/en-GB/support/declarations-of-conformity>.

This Class A digital apparatus complies with Canadian ICES-003. Cet appareil numérique de la classe A est conforme à la norme NMB-003 du Canada.

Canada, ISED Notice

Notice: The Industry Canada regulations provide that changes or modifications not expressly approved by Shure Inc. could void your authority to operate this equipment.