

ARCADIA freestanding screens specification sheet

XPO SCREENS



- ➔ Versatile sizes
- ➔ Touch option
- ➔ Multi-OS compatibility
- ➔ Integrated media players
- ➔ Built-in IR sensors
- ➔ Sleek and sturdy design
- ➔ Safety glass
- ➔ Interactive experience
- ➔ Customizable design

Welcome to the future of dynamic displays with ARCADIA, where cutting-edge innovation meets unparalleled audience engagement. Its sleek 35mm steel frame, safety glass, and robust housing ensure both durability and style, while the customizable design adds a touch of uniqueness to complement your brand or environment seamlessly.

ARCADIA offers seamless integration with all types of mediaplayers and OS platforms, making content management a breeze with the option to install almost any common player in the foot. Take interactivity to new heights with optional IR sensors and a touch interface, providing a truly immersive and intuitive experience.



Available in three different sizes

We offer the ARCADIA in 32, 46, and 55-inch variants. Custom sizes are available upon request, and frame height adjustments can also be accommodated.

Multifunctional base

ARCADIA's specially designed base allows for easy integration of various media player formats, seamlessly incorporating your own type of player within the housing.

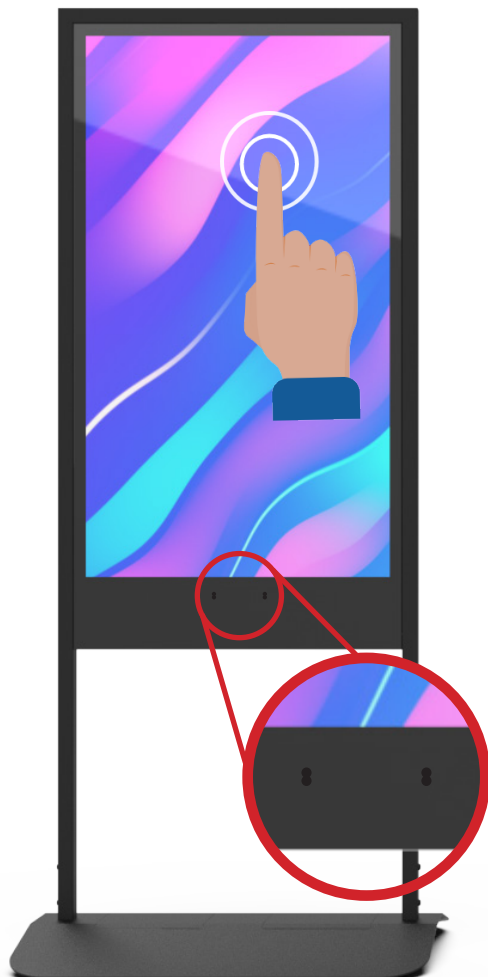

Available with touch

Unleash interactivity and elevate engagement with our touch-enabled freestanding display. Seamlessly integrated with responsive touch technology, it offers a dynamic and immersive experience, empowering users to interact directly with content. From presentations to interactive kiosks, the touch version adds accessibility and interactivity, making every interaction remarkable.

Optional IR Sensors

Enhance your ARCADIA screens with integrated proximity sensors, providing sustainable automatic on/off functionality and seamless content transitions when a person approaches. For instance, effortlessly switch from digital signage content to interactive touch applications.

Optional player platforms

Our screen solutions offer you the freedom to select the player platform and operating system (OS) of your choice.



BrightSign

BrightSign OS stands out in digital signage for its purpose-built design, delivering high-performance playback and reliability. With features such as robust content management, remote monitoring, and a user-friendly interface, BrightSign OS ensures a seamless and efficient experience for creating and managing dynamic digital signage content across a variety of applications.



Android 9 for digital signage stands out with its user-friendly interface and robust performance, offering seamless integration with a wide range of applications and devices. Its advanced security features and efficient resource management ensure a reliable and secure operating system for powering dynamic and engaging digital signage displays.



Windows IoT excels in digital signage by providing a versatile and familiar platform, allowing for easy integration with Windows applications and services. Its robust security features, remote device management capabilities, and compatibility with a variety of hardware make Windows IoT a powerful choice for creating reliable and customizable digital signage solutions.

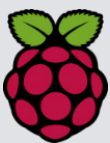

The Raspberry Pi OS for digital signage offers cost-effectiveness and versatility, leveraging the compact yet powerful Raspberry Pi hardware. Its community-driven support, energy efficiency, and compatibility with various applications make it a standout choice for creating affordable and customizable digital signage solutions.



Chrome OS for digital signage provides a streamlined and secure platform, leveraging the simplicity of the Chrome ecosystem. With automatic updates, cloud-based management, and a user-friendly interface, Chrome OS ensures a hassle-free and reliable solution for deploying and maintaining digital signage displays at scale.

Harmony in design

Preserve your meticulous interior design with ARCADIA. Achieve seamless integration by customizing the frame, glass print, and logo to match your preferred design, ensuring a harmonious blend.



ARCADIA freestanding screens measurements 32 inch

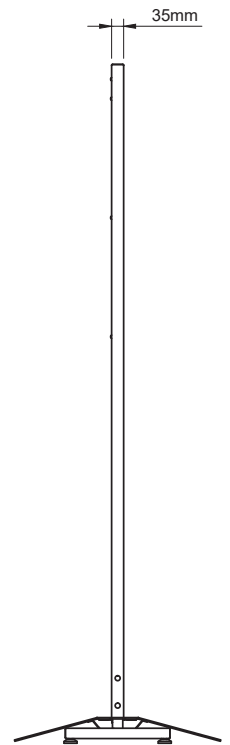
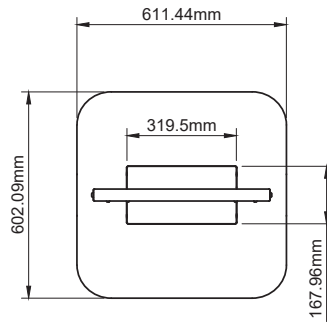
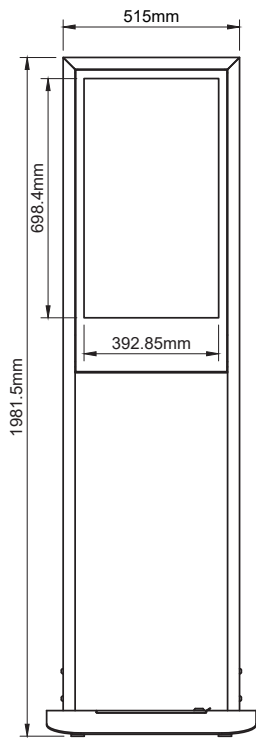

Panel Specifications	
Panel Brightness	500 cd/m ²
Contrast Ratio	4000:1 (Typ.)
Display resolution	1920 x 1080
Viewing Angle	89/89/89/89 (Typ.)
Pixel Pitch	363.7 x 363.7
Frame Rate	60Hz
Power	
Power supply	100-240VAC/ 50/60Hz
Operating voltage	24V DC
Power adapter	90W
Power consumption (typical)	55W
Warranty	
Warranty period	3 year warranty (ship-in)
Lifetime TFT panel	50.000 hours
Environmental	
Operating temperature	10 to 40 Celsius
Operating humidity	10-80%, non-condensing
IP rating	IP53
Transport and storage	
Device weight	40kg/88lb
Package weight	Depends on order Quantity and crating
Storage temperature	-20 to +45 Celsius
Storage humidity	5-95%, non-condensing
Protection glass	
Glass used in our Displays	5mm thermally tempered safety glass
Options	
Touch	Projected capacitive multitouch
Extended warranty period	5 year warranty
Anti-Glare glass	4mm thermally tempered anti-glare safety glass

ARCADIA freestanding screens measurements 46 inch

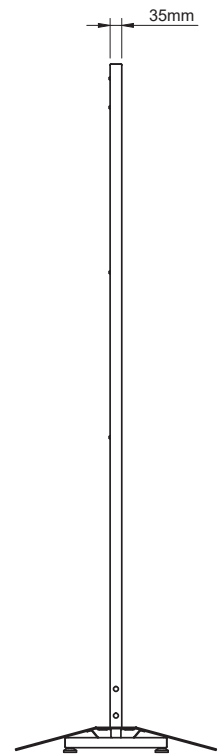
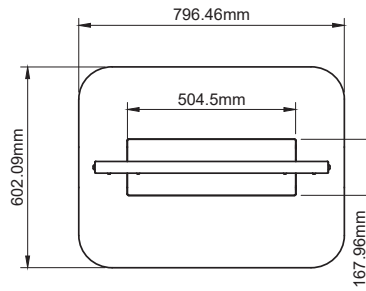
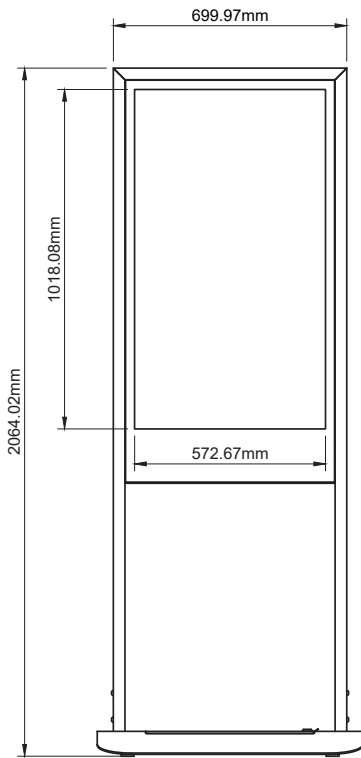

Panel Specifications	
Panel Brightness	700 cd/m ²
Contrast Ratio	4000:1 (Typ.)
Display resolution	1920 x 1080
Viewing Angle	89/89/89/89 (Typ.)
Pixel Pitch	530.25 x 530.25
Frame Rate	60Hz
Power	
Power supply	100-240VAC/ 50/60Hz
Operating voltage	24V DC
Power adapter	120W
Power consumption (typical)	96W
Warranty	
Warranty period	3 year warranty (ship-in)
Lifetime TFT panel	50.000 hours
Environmental	
Operating temperature	10 to 40 Celsius
Operating humidity	10~80%, non-condensing
IP rating	IP53
Transport and storage	
Device weight	60kg/132lb
Package weight	Depends on order quantity and crating
Storage temperature	-20 to +45 Celsius
Storage humidity	5~95%, non-condensing
Protection glass	
Glass used in our Displays	5mm thermally tempered safety glass
Options	
Touch	On request with MOQ
Extended warranty period	5 year warranty
Anti-Glare glass	4mm thermally tempered anti-glare safety glass

ARCADIA freestanding screens measurements 55 inch

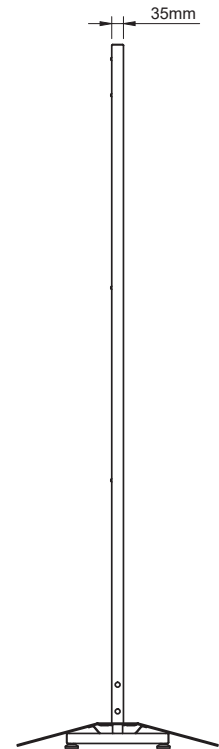
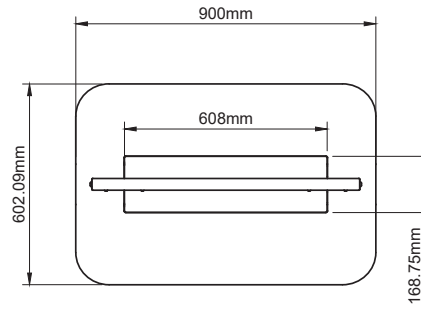
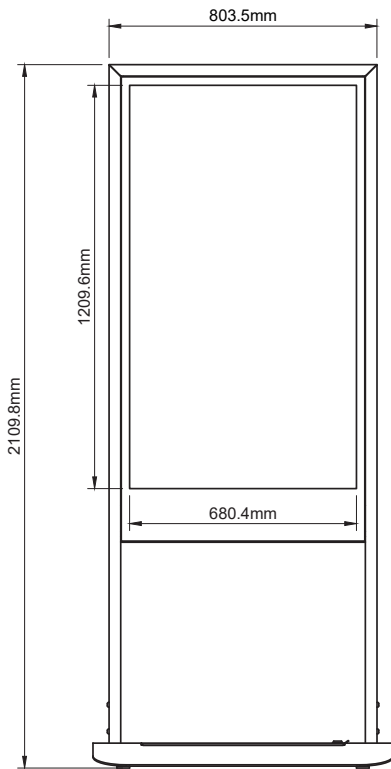

Panel Specifications	
Panel Brightness	450 cd/m ²
Contrast Ratio	4000:1 (Typ.)
Display resolution	1920 x 1080
Viewing Angle	89/89/89/89 (Typ.)
Pixel Pitch	630 x 630
Frame Rate	60Hz
Power	
Power supply	100-240VAC/ 50/60Hz
Operating voltage	24V DC
Power adapter	120W
Power consumption (typical)	103W
Warranty	
Warranty period	3 year warranty (ship-in)
Lifetime TFT panel	50.000 hours
Environmental	
Operating temperature	10 to 40 Celsius
Operating humidity	10-80%, non-condensing
IP rating	IP53
Transport and storage	
Device weight	68kg/149.6lb
Package weight	Depends on order quantity and crating
Storage temperature	-20 to +45 Celsius
Storage humidity	5-95%, non-condensing
Protection glass	
Glass used in our Displays	5mm thermally tempered safety glass
Options	
Touch	Projected capacitive multitouch
Extended warranty period	5 year warranty
Anti-Glare glass	4mm thermally tempered anti-glare safety glass

measurements for the player and cable management

32"

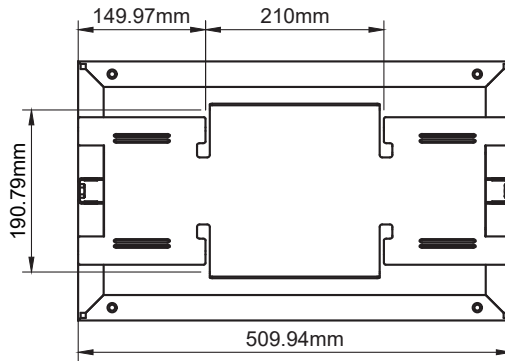

46"

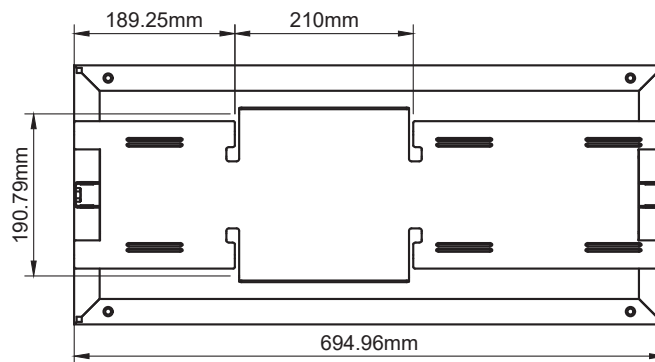

55"

