

## 1 Floor Mounting Option - Freestanding

## 1A Floor Mounting Option - Bolt To Floor

COMPLETE STEP 1

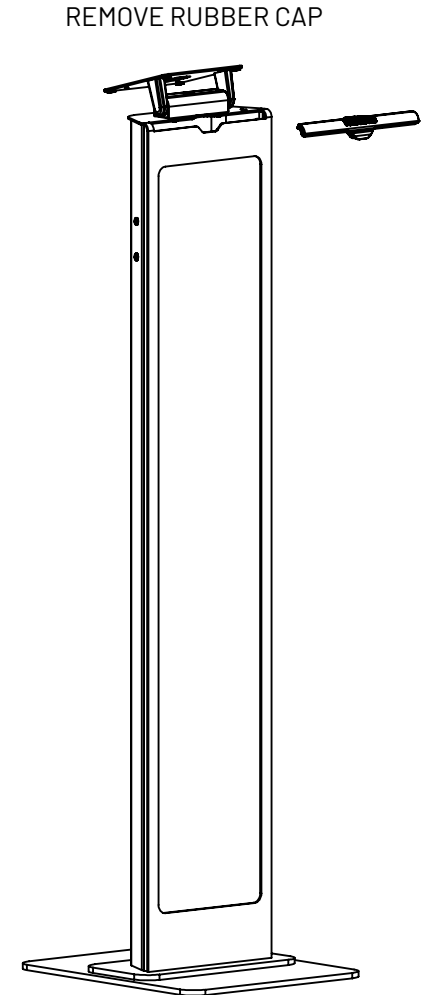
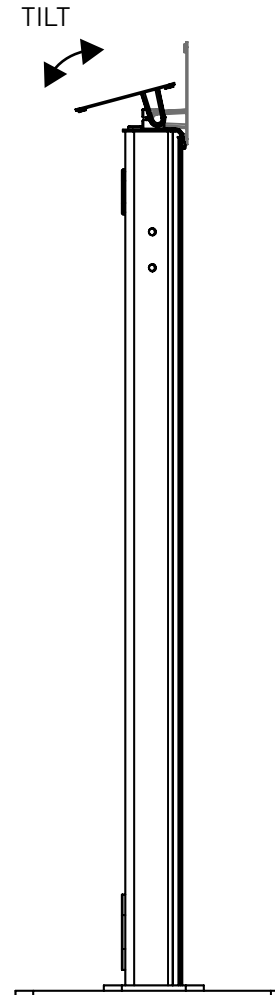
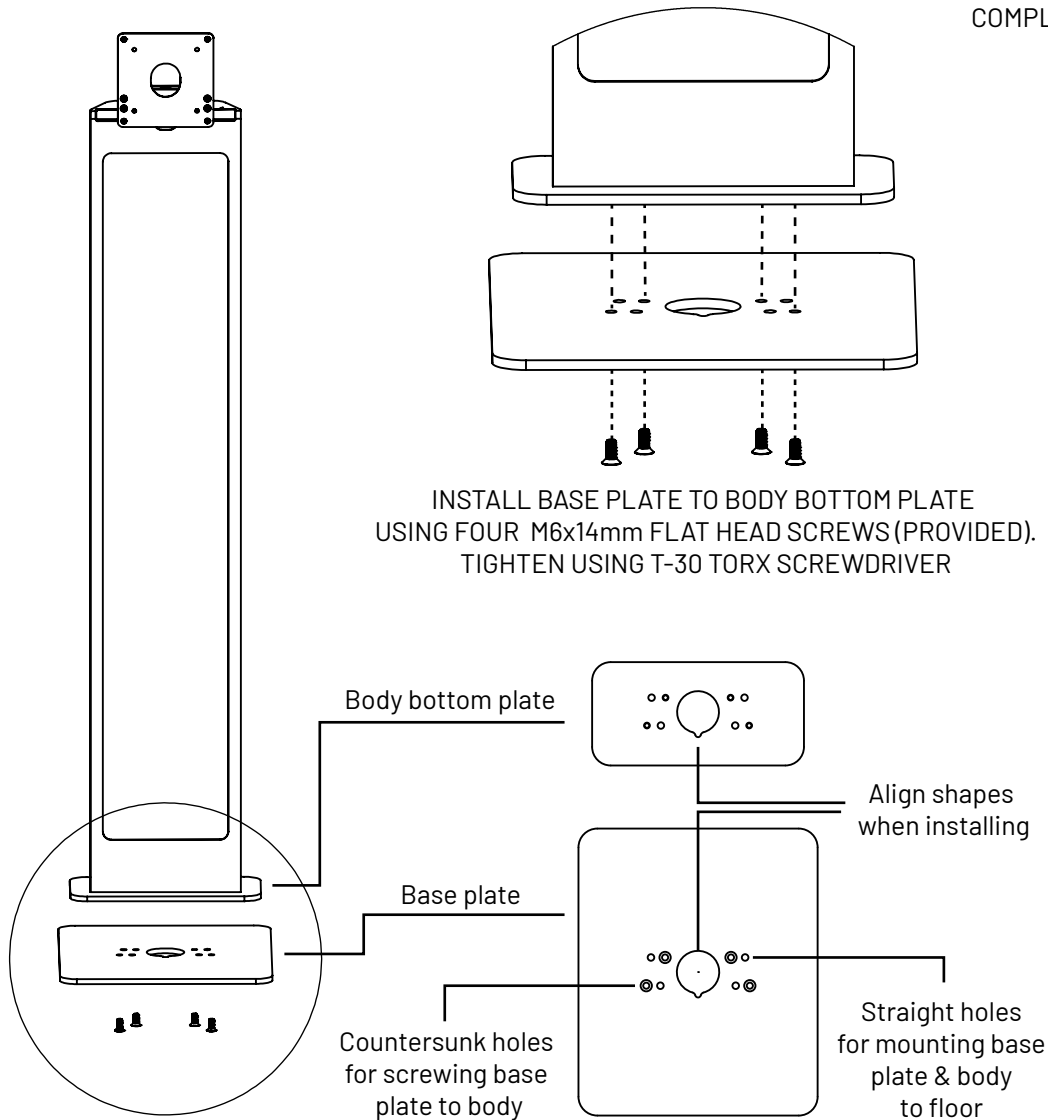

\*NOTE: FLOOR STAND MUST BE TRANSPORTED WITHOUT THE STABILITY PLATE ATTACHED TO PREVENT DAMAGE.

## 1A - Continued

TAKE OUT COVER PANEL

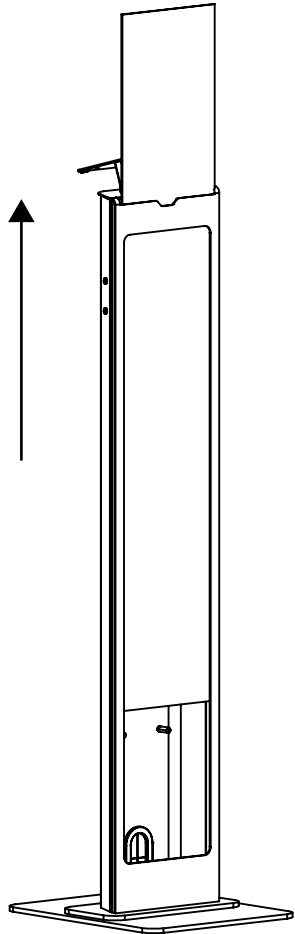

BOTTOM PLATE SIZE

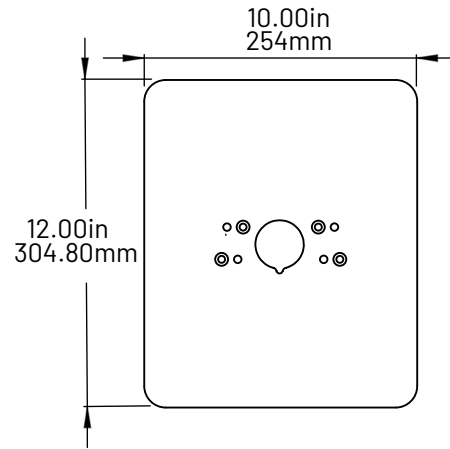

FLOOR MOUNTING PATTERN

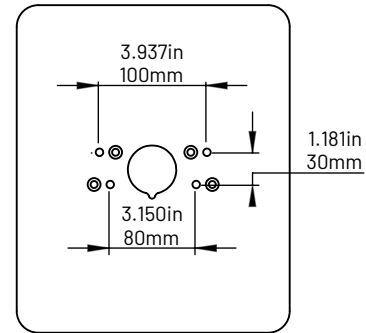

PUT THE COVER PANEL BACK

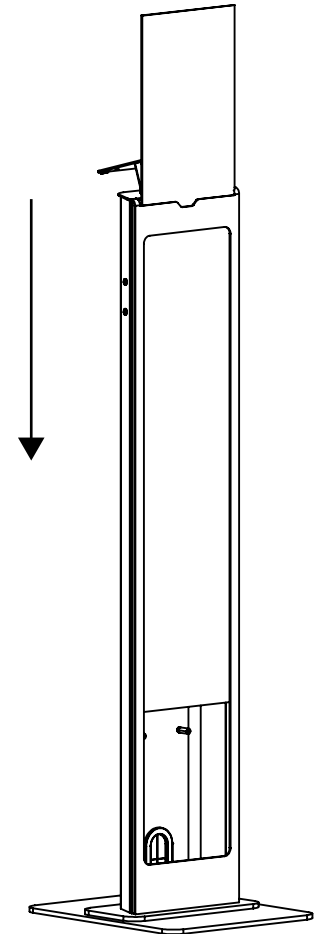

LOCATE SCREW HOLES IN BODY  
BOTTOM PLATE  
BOLT TO FLOOR USING  
APPROPRIATE BOLTS  
FOR FLOOR TYPE (NOT PROVIDED)

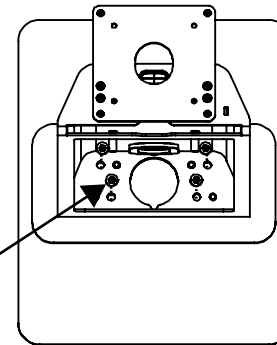

## 2 Cable Management Options

REMOVE RUBBER CAP

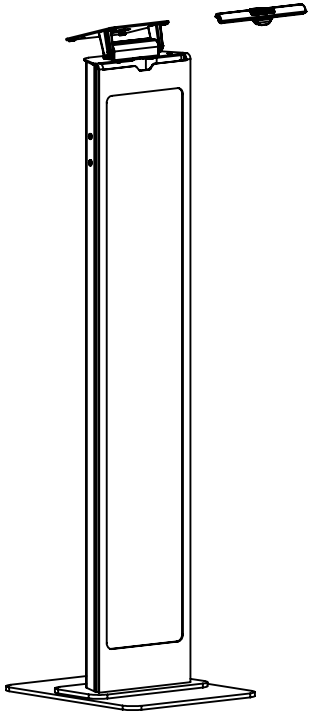

TAKE OUT COVER PANEL

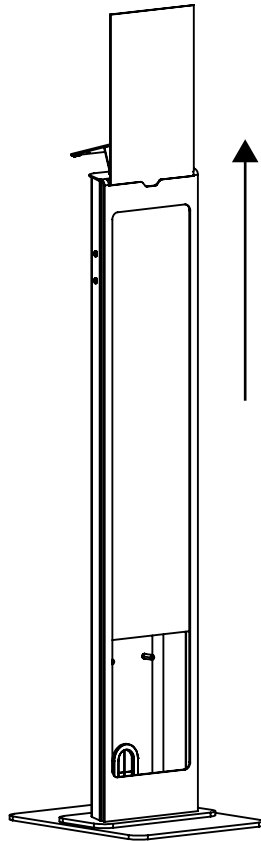

A - INLET IN TOP PLATE  
B - INLET IN BACK PLATE  
C - EXIT IN BACK PLATE  
D - EXIT IN BASE PLATE

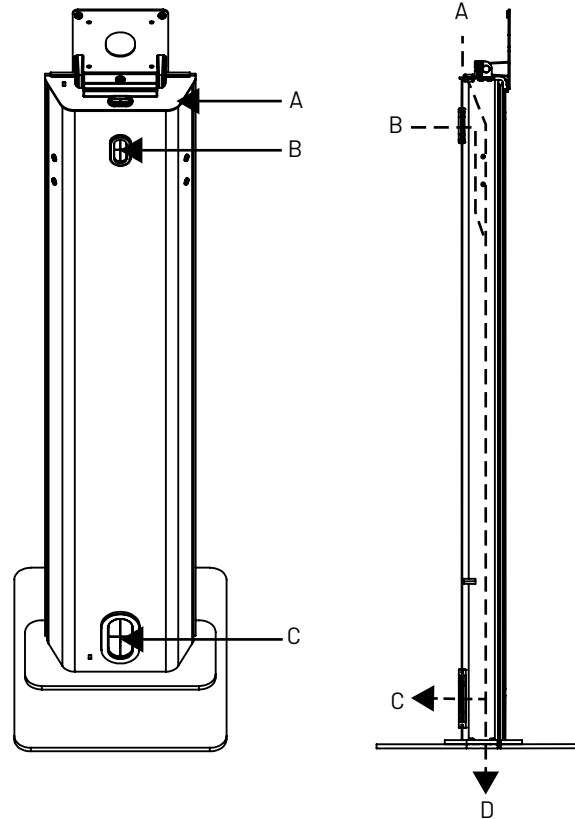

1. PUT THE COVER PANEL BACK  
2. PUT BACK THE RUBBER CAP\*

\*for easier insertion of the rubber cap,  
use a flat head screwdriver or similiar  
object to adjust the cap.

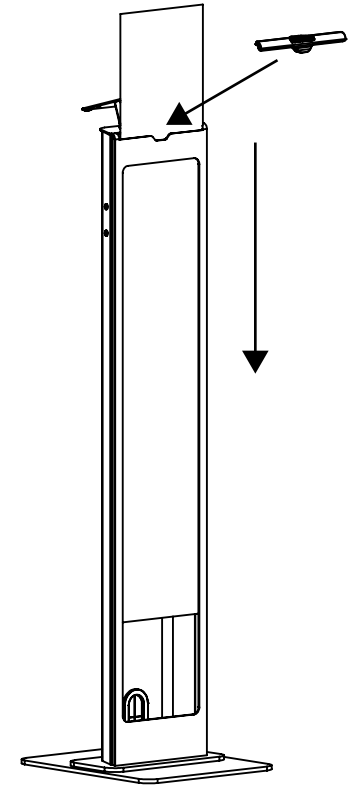

3A Install Device

3B

INSTALL YOUR TABLET ENCLOSURE  
(OR VESA COMPATIBLE MOUNTING SOLUTION)  
USING FOUR M4x8mm PHILLIPS PAN HEAD SCREWS (PROVIDED)

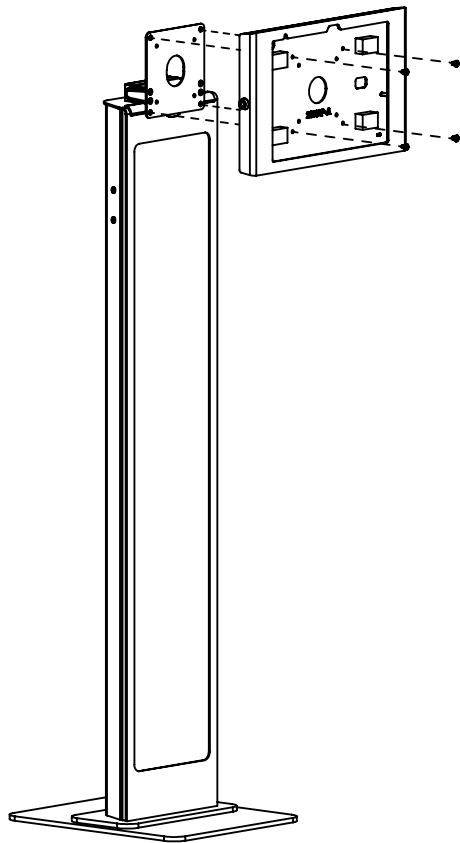

ADJUST TILT RESISTANCE BY  
TIGHTENING THE SCREW LOCATED  
ON THE HINGE ASSEMBLY

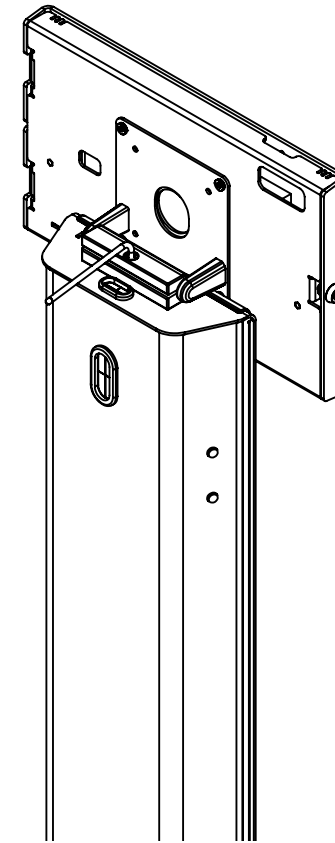

Graphic Panel Specifications

In The Box

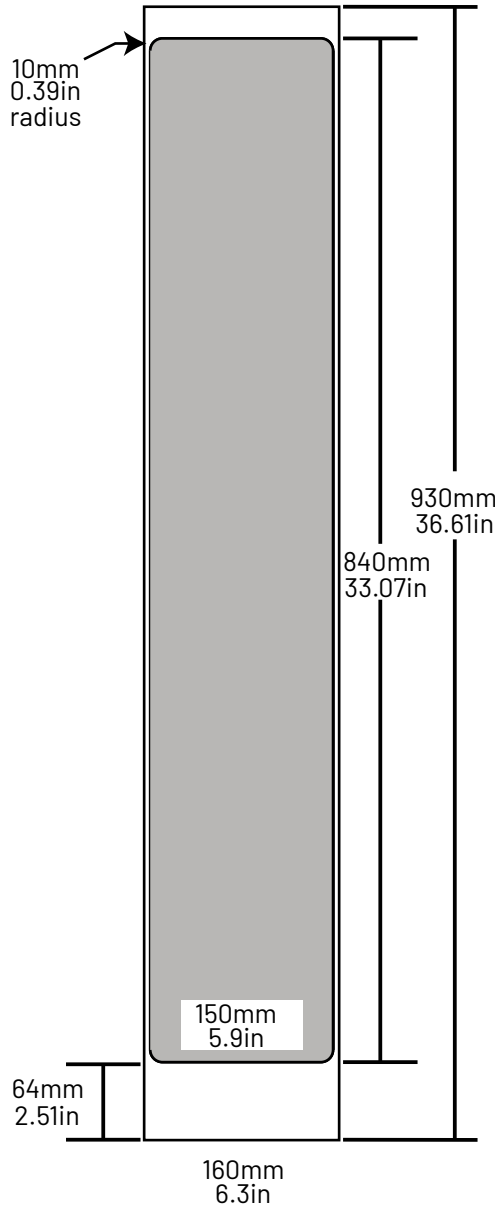

panel information:  
 Graphics panel thickness  
 5mm ±5% max  
 .02in±5% max

Panel material examples:  
 Backlit: clear acrylic/polycarbonate\*  
 Standard: foam board, foamed PVC panel\*

\*examples only, consult chosen printing services for recommended material and print methods.

