



ETSI EN 300 328 V2.1.1 (2016-11) SECTIONS 4.3.2.9 AND 4.3.2.10

TEST REPORT

FOR

Internet of Things Amplifier Connection Series

MODEL: Connect Series 704D

REPORT NUMBER: R12777555-E1

ISSUE DATE: 2020-02-21

**Prepared for
LEA PROFESSIONAL
635 S. LAFAYETTE BLVD, BUILDING 113, SUITE 109
SOUTH BEND, IN 46601, USA**

**Prepared by
UL LLC
12 LABORATORY DR.
RESEARCH TRIANGLE PARK, NC 27709 USA
TEL: (919) 549-1400**



REVISION HISTORY

Ver.	Issue Date	Revisions	Revised By
1	2020-02-21	Initial Issue	

TABLE OF CONTENTS

REVISION HISTORY	2
TABLE OF CONTENTS	3
1. ATTESTATION OF TEST RESULTS.....	4
2. SUMMARY OF TEST RESULTS	6
3. TEST METHODOLOGY	7
4. FACILITIES AND ACCREDITATION.....	7
5. CALIBRATION AND UNCERTAINTY	7
5.1. MEASURING INSTRUMENT CALIBRATION	7
5.2. MEASUREMENT UNCERTAINTY	7
6. EQUIPMENT UNDER TEST	8
6.1. DESCRIPTION OF EUT.....	8
6.2. MAXIMUM EIRP.....	8
6.3. DESCRIPTION OF AVAILABLE ANTENNAS.....	8
6.5. WORST-CASE CONFIGURATION AND MODE.....	8
6.6. DESCRIPTION OF TEST SETUP.....	9
7. TEST AND MEASUREMENT EQUIPMENT	11
8. NORMAL CONDITIONS	12
9. TEST RESULTS.....	13
9.1. TX UNWANTED EMISSIONS IN THE SPURIOUS DOMAIN	13
9.1.1. 802.11b MODE 2412 MHz	14
9.1.2. 802.11b MODE 2472 MHz	15
9.1.3. 802.11g MODE 2412 MHz	16
9.1.4. 802.11g MODE 2472 MHz	17
9.2. RECEIVER SPURIOUS EMISSIONS	18
9.2.1. RECEIVE MODE LOW CHANNEL 2412MHZ.....	19
10. SETUP PHOTOS.....	21
END OF TEST REPORT	23

1. ATTESTATION OF TEST RESULTS

COMPANY NAME: LEA Professional
635 S. Lafayette Blvd, Building 113, Suite 109
South Bend, IN 46601, USA

EUT DESCRIPTION: Internet of Things Amplifier Connection Series

MODEL: Connect Series 704D

SERIAL NUMBER: 298190007

RECEIVED DATE: 2020-02-04

DATE TESTED: 2020-02-04 to 2020-02-05

APPLICABLE STANDARDS	
STANDARD	TEST RESULTS
ETSI EN 300 328 V2.1.1 (2016-11) Sections 4.3.2.9 AND 4.3.2.10	Refer to Section 2



UL LLC tested the above equipment in accordance with the requirements set forth in the above standards. The test results show that the equipment tested is capable of demonstrating compliance with the requirements as documented in this report.

The results documented in this report apply only to the tested sample, under the conditions and modes of operation as described herein. It is the manufacturer's responsibility to assure that additional production units of this model are manufactured with identical electrical and mechanical components. All samples tested were in good operating condition throughout the entire test program. Measurement Uncertainties are published for informational purposes only and were not taken into account unless noted otherwise.

This document may not be altered or revised in any way unless done so by UL LLC and all revisions are duly noted in the revisions section. Any alteration of this document not carried out by UL LLC will constitute fraud and shall nullify the document. This report must not be used by the client to claim product certification, approval, or endorsement by NVLAP, NIST, or any agency of the U.S. Government.

Approved & Released
For UL LLC By:

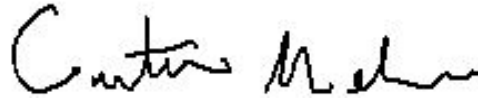
Prepared By:



Brian Kiewra
Project Engineer
Consumer Technology Division
UL LLC

Cristian Melara
Engineer
Consumer Technology Division
UL LLC

2. SUMMARY OF TEST RESULTS

Requirement Description	Requirement Clause Number	Result	Remarks
RF Output Power	4.3.2.2	Not tested	See Note 1
Power Spectral Density	4.3.2.3		
Duty cycle, Tx-Sequence, Tx-gap	4.3.2.4		
Medium Utilization	4.3.2.5		
Adaptivity	4.3.2.6		
Occupied Channel Bandwidth	4.3.2.7		
Transmitter unwanted emissions in the OOB domain	4.3.2.8	Compliant	
Transmitter unwanted emissions in the spurious domain	4.3.2.9	Compliant	
Receiver spurious emissions	4.3.2.10	Compliant	
Receiver Blocking	4.3.2.11	Not tested	
Geo-location capability	4.3.2.12		

Note 1: Radiated spurious spot checks performed to ensure radio module remains compliant when installed in host EUT. It is the responsibility of the host manufacturer to provide the radio module test reports upon request. Refer to module report for test results.

3. TEST METHODOLOGY

All tests were performed in accordance with the procedures documented in ETSI EN 300 328 V2.1.1 (2016-11).

4. FACILITIES AND ACCREDITATION

The test sites and measurement facilities used to collect data are located at 12 Laboratory Drive, Research Triangle Park, NC 27709, USA and 2800 Perimeter Park Dr., Suite B, Morrisville, NC 27560, USA. The following table identifies which facilities were utilized for radiated emission measurements documented in this report. Specific facilities are also identified in the test results sections.

12 Laboratory Dr.	2800 Perimeter Park Dr.
<input type="checkbox"/> Chamber A	<input checked="" type="checkbox"/> Chamber North
<input type="checkbox"/> Chamber C	<input type="checkbox"/> Chamber South

UL LLC is accredited by NVLAP, Laboratory Code 200246-0.

5. CALIBRATION AND UNCERTAINTY

5.1. MEASURING INSTRUMENT CALIBRATION

The measuring equipment utilized to perform the tests documented in this report has been calibrated in accordance with the manufacturer's recommendations, and is traceable to recognized national standards.

5.2. MEASUREMENT UNCERTAINTY

Where relevant, the following measurement uncertainty levels have been estimated for tests performed on the apparatus:

PARAMETER	UNCERTAINTY
All emissions, radiated	$\pm 4.88\text{dB}$

Uncertainty figures are valid to a confidence level of 95%.

6. EQUIPMENT UNDER TEST

6.1. DESCRIPTION OF EUT

The EUT is an internet of things amplifier connection series. The EUT contains a 2.4GHz WLAN radio.

6.2. MAXIMUM EIRP

EIRP not measured in this report. Radiated spurious spot checks performed to ensure radio module remains compliant when installed in host EUT. For the testing contained in this report, the transmission power levels of the radio module was set at the levels intended to be used by the end product manufacturer. It is the responsibility of the end product manufacturer to ensure the end product power levels are the same or lower than the power levels found in the module report and to provide the radio module test reports upon request.

6.3. DESCRIPTION OF AVAILABLE ANTENNAS

The radio utilizes a FlexPIFA antenna with antenna gain of 2.0 dBi.

6.4. SOFTWARE AND FIRMWARE

The test utility software used during testing was Microchip serial bridge "MCHPRT" V1.4.6.4.

6.5. WORST-CASE CONFIGURATION AND MODE

Transmit radiated emissions between 30MHz and 12.75GHz were performed with the EUT set to transmit at the highest power on channels 2412MHz and 2472MHz.

Receive radiated spurious emissions between 30MHz and 12.75GHz were performed with the EUT set to receiver mode on mode on channel 2412MHz and 2472GHz

The selected EUT configuration was chosen to maximize emissions. EUT intended to operate in only one orientation. Therefore, all testing performed with the EUT in its intended orientation

Worst-case data rates as provided by the client were:

802.11b mode: 1 Mbps

802.11g mode: 6 Mbps

6.6. DESCRIPTION OF TEST SETUP
SUPPORT EQUIPMENT

Use	Product Type	Manufacturer	Model	Comments
EUT	Amplifier	LEA Professional	DANTE Enabled	None
Note: EUT - Equipment Under Test, AE - Auxiliary/Associated Equipment, or SIM - Simulator (Not Subjected to Test)				

I/O CABLES

Port #	Name	Type*	Cable Max. >3m (Y/N)	Cable Shielded (Y/N)	Comments
0	Enclosure	N/E	—	—	None
1	Mains	AC	N	N	None
2	Debug Cable	I/O	N	N	Cable used for radio control purposes only. Not connected during testing.
*Note: AC = AC Power Port DC = DC Power Port N/E = Non-Electrical I/O = Signal Input or Output Port (Not Involved in Process Control) TP = Telecommunication Ports					

TEST SETUP

The EUT is configured as a standalone device.

SETUP DIAGRAM FOR TESTS

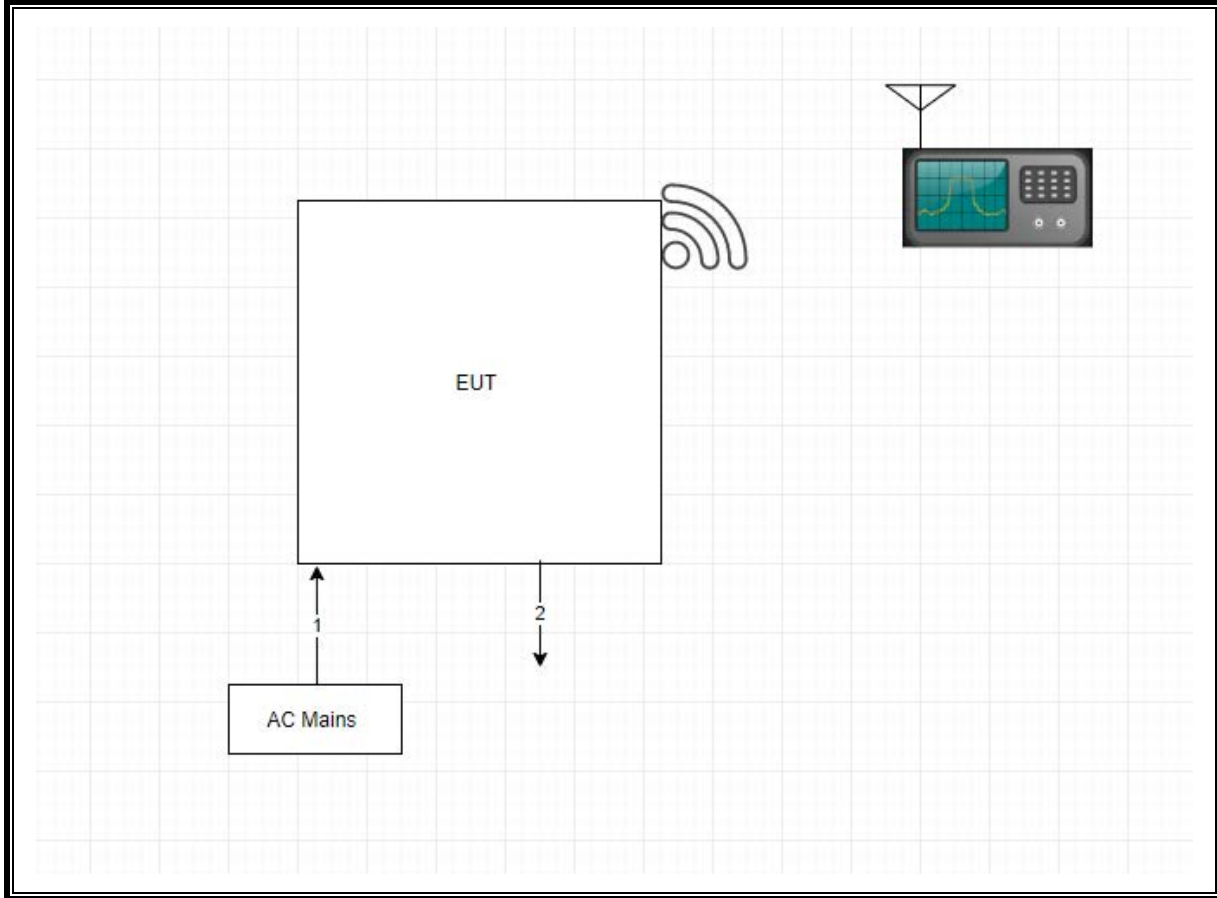

7. TEST AND MEASUREMENT EQUIPMENT

The following test and measurement equipment were utilized for the tests documented in this report:

Test Equipment Used - Radiated Disturbance Emissions Test Equipment (Morrisville - North Chamber)

Equip. ID	Description	Manufacturer	Model Number	Last Cal.	Next Cal.
	30-1000 MHz				
AT0073	Hybrid Broadband Antenna	Sunol Sciences Corp.	JB3	2019-008-08	2020-08-08
	1-18 GHz				
AT0067	Double-Ridged Waveguide Horn Antenna, 1 to 18 GHz	ETS Lindgren	3117	2019-03-22	2020-03-22
	Gain-Loss Chains				
N-SAC02	Gain-loss string: 25-1000MHz	Various	Various	2019-05-02	2020-05-02
N-SAC03	Gain-loss string: 1-18GHz	Various	Various	2019-03-15	2020-03-15
	Receiver & Software				
SA0026	Spectrum Analyzer	Agilent	N9030A	2019-03-19	2020-03-19
SOFTEMI	EMI Software	UL	Version 9.5 June 11, 2019	NA	NA
	Additional Equipment used				
s/n 181474341	Environmental Meter	Fisher Scientific	15-077-963	2018-07-27	2020-07-27
PS215	AC Power Source	Elgar	CW2501M (s/n 1523A02397)	NA	NA
BRF003	2.4GHz notch filter, 2W, F _{high} =18GHz	Micro-Tronics	BRM50702	2019-06-14	2020-06-14

8. NORMAL CONDITIONS

LIMITS

None; for reporting purposes only.

RESULTS

Nominal temperature (see table below)

Test Item	Normal Temperature during test (°C)	Allowed Range (°C)	Normal Humidity during test (%)	Allowed Range (%)
Transmitter unwanted emissions in the spurious domain	23.4 °C	+15 °C to 35 °C	26.5%	20 % to 75 %
Receiver spurious emissions	23.4 °C	+15 °C to 35 °C	26.5%	20 % to 75 %

9. TEST RESULTS

9.1. TX UNWANTED EMISSIONS IN THE SPURIOUS DOMAIN

LIMIT

ETSI EN 300 328 V2.1.1 (2016-11) Clause 4.3.2.9.3

The transmitter unwanted emissions in the spurious domain shall not exceed the values given in table 12 below.

In case of equipment with antenna connectors, these limits apply to emissions at the antenna port (conducted). For emissions radiated by the cabinet or emissions radiated by integral antenna equipment (without antenna connectors), these limits are e.r.p. for emissions up to 1 GHz and as e.i.r.p. for emissions above 1 GHz.

Table 12: Transmitter limits for spurious emissions

Frequency range	Maximum power	Bandwidth
30 MHz to 47 MHz	-36 dBm	100 kHz
47 MHz to 74 MHz	-54 dBm	100 kHz
74 MHz to 87,5 MHz	-36 dBm	100 kHz
87,5 MHz to 118 MHz	-54 dBm	100 kHz
118 MHz to 174 MHz	-36 dBm	100 kHz
174 MHz to 230 MHz	-54 dBm	100 kHz
230 MHz to 470 MHz	-36 dBm	100 kHz
470 MHz to 862 MHz	-54 dBm	100 kHz
862 MHz to 1 GHz	-36 dBm	100 kHz
1 GHz to 12,75 GHz	-30 dBm	1 MHz

TEST PROCEDURE

ETSI EN 300 328 V2.1.1 (2016-11) Clause 5.4.9.2.2

TEST CONDITION

ETSI EN 300 328 V2.1.1 (2016-11) 5.4.9.1

The level of spurious emissions shall be measured as, either:

- a) their power in a specified load (conducted spurious emissions) and their effective radiated power when radiated by the cabinet or structure of the equipment (cabinet radiation); or
- b) their effective radiated power when radiated by cabinet and antenna in case of integral antenna equipment with no antenna connectors.

Note: For testing the device covered by this report, test condition (a) was used. All measurements are PK, unless margin <-6dB, which warrants a follow-up RMS measurement.

9.1.1. 802.11b MODE 2412 MHz
RADIATED SPURIOUS EMISSIONS BELOW 1 GHz

Project Number:	12777555
Client:	LEA
Test Location:	N-SAC
Mode:	1Tx, 11b 2412MHz
Tested by:	11993
Date:	2020-02-05

Marker	Frequency (MHz)	Meter Reading (dBm)	Det	PL (dB)	Corrected Reading ERP (dBm)	ETSI EN Tx Spurious (dBm)	Margin (dB)	Azimuth (Degs)	Height (cm)	Polarity
1	181.9981	-63.21	Pk	-7.5	-70.71	-54	-16.71	0-360	98	H
2	201.0001	-67.9	Pk	-6.1	-74	-54	-20	0-360	102	H
3	855.4893	-78.17	Pk	5.8	-72.37	-54	-18.37	0-360	399	H
4	181.9981	-67.59	Pk	-4.1	-71.69	-54	-17.69	0-360	199	V
5	201.0001	-73.68	Pk	-3.5	-77.18	-54	-23.18	0-360	199	V
6	851.9891	-77.75	Pk	8.1	-69.65	-54	-15.65	0-360	299	V

Pk - Peak detector

RADIATED SPURIOUS EMISSIONS ABOVE 1 GHz

Project Number:	12777555
Client:	LEA
Test Location:	N-SAC
Mode:	1Tx, 11b, 2412MHz
Tested by:	11993
Date:	2020-02-04

Marker	Frequency (GHz)	Meter Reading (dBm)	Det	Path-Loss (dB)	Filter (dB)	Corrected Reading EIRP (dBm)	ETSI EN Tx Spurious (dBm)	Margin (dB)	Azimuth (Degs)	Height (cm)	Polarity
1	3.2228	-64.13	Pk	10.9	.7	-52.53	-30	-22.53	0-360	198	H
2	3.79956	-64.86	Pk	12.3	.4	-52.16	-30	-22.16	0-360	148	H
3	4.80129	-64.59	Pk	13.7	.4	-50.49	-30	-20.49	0-360	148	H
4	3.01472	-63.88	Pk	10.9	.8	-52.18	-30	-22.18	0-360	198	V
5	3.54007	-64.1	Pk	11.8	.4	-51.9	-30	-21.9	0-360	152	V
6	4.81891	-64.63	Pk	13.8	.4	-50.43	-30	-20.43	0-360	152	V

Pk - Peak detector

9.1.2. 802.11b MODE 2472 MHz
RADIATED SPURIOUS EMISSIONS BELOW 1 GHz

Project Number:	12777555
Client:	LEA
Test Location:	N-SAC
Mode:	1Tx, 11g, 2472MHz
Tested by:	11993
Date:	2020-02-05

Marker	Frequency (MHz)	Meter Reading (dBm)	Det	PL (dB)	Corrected Reading ERP (dBm)	ETSI EN Tx Spurious (dBm)	Margin (dB)	Azimuth (Degs)	Height (cm)	Polarity
1	181.9768	-63.11	Pk	-7.5	-70.61	-54	-16.61	0-360	98	H
2	206.0004	-64.85	Pk	-6.1	-70.95	-54	-16.95	0-360	101	H
3	839.7884	-78.22	Pk	5.5	-72.72	-54	-18.72	0-360	299	H
4	181.9768	-68.01	Pk	-4.1	-72.11	-54	-18.11	0-360	199	V
5	734.082	-76.82	Pk	6.2	-70.62	-54	-16.62	0-360	199	V
6	831.4879	-77.62	Pk	7.9	-69.72	-54	-15.72	0-360	299	V

Pk - Peak detector

RADIATED SPURIOUS EMISSIONS ABOVE 1 GHz

Project Number:	12777555
Client:	LEA
Test Location:	N-SAC
Mode:	1Tx, 11g, 2472MHz
Tested by:	11993
Date:	2020-02-04

Marker	Frequency (GHz)	Meter Reading (dBm)	Det	Path-Loss (dB)	Filter (dB)	Corrected Reading EIRP (dBm)	ETSI EN Tx Spurious (dBm)	Margin (dB)	Azimuth (Degs)	Height (cm)	Polarity
1	3.26442	-64.53	Pk	11	.7	-52.83	-30	-22.83	0-360	198	H
2	3.77948	-64.65	Pk	12.2	.3	-52.15	-30	-22.15	0-360	152	H
3	4.83262	-64.8	Pk	13.8	.3	-50.7	-30	-20.7	0-360	152	H
4	3.025	-63.88	Pk	10.9	.8	-52.18	-30	-22.18	0-360	152	V
5	3.62917	-65.11	Pk	12	.4	-52.71	-30	-22.71	0-360	152	V
6	4.82723	-64.71	Pk	13.8	.3	-50.61	-30	-20.61	0-360	152	V

Pk - Peak detector

9.1.3. 802.11g MODE 2412 MHz
RADIATED SPURIOUS EMISSIONS BELOW 1 GHz

Project Number:	12777555
Client:	LEA
Test Location:	N-SAC
Mode:	1Tx, 11g, 2412MHz
Tested by:	11993
Date:	2020-02-05

Marker	Frequency (MHz)	Meter Reading (dBm)	Det	PL (dB)	Corrected Reading ERP (dBm)	ETSI EN Tx Spurious (dBm)	Margin (dB)	Azimuth (Degs)	Height (cm)	Polarity
1	182.0193	-63.18	Pk	-7.5	-70.68	-54	-16.68	0-360	98	H
2	201.0001	-66.34	Pk	-6.1	-72.44	-54	-18.44	0-360	102	H
3	851.0891	-77.68	Pk	5.7	-71.98	-54	-17.98	0-360	102	H
4	182.0193	-68.36	Pk	-4.1	-72.46	-54	-18.46	0-360	199	V
5	201.0001	-72.04	Pk	-3.5	-75.54	-54	-21.54	0-360	199	V
6	841.9885	-78.14	Pk	8	-70.14	-54	-16.14	0-360	199	V

Pk - Peak detector

RADIATED SPURIOUS EMISSIONS ABOVE 1 GHz

Project Number:	12777555
Client:	LEA
Test Location:	N-SAC
Mode:	1Tx, 11g, 2412MHz
Tested by:	11993
Date:	2020-02-04

Marker	Frequency (GHz)	Meter Reading (dBm)	Det	Path-Loss (dB)	Filter (dB)	Corrected Reading EIRP (dBm)	ETSI EN Tx Spurious (dBm)	Margin (dB)	Azimuth (Degs)	Height (cm)	Polarity
1	3.13957	-64.72	Pk	10.6	.8	-53.32	-30	-23.32	0-360	152	H
2	3.94546	-64.93	Pk	12.7	.4	-51.83	-30	-21.83	0-360	198	H
3	4.82185	-65.36	Pk	13.8	.4	-51.16	-30	-21.16	0-360	152	H
4	3.12733	-63.19	Pk	11.1	.7	-51.39	-30	-21.39	0-360	198	V
5	3.98952	-65.25	Pk	12.6	.3	-52.35	-30	-22.35	0-360	198	V
6	4.80961	-64.96	Pk	13.7	.4	-50.86	-30	-20.86	0-360	198	V

Pk - Peak detector

9.1.4. 802.11g MODE 2472 MHz
RADIATED SPURIOUS EMISSIONS BELOW 1 GHz

Project Number:	12777555
Client:	LEA
Test Location:	N-SAC
Mode:	1Tx, 11g, 2472MHz
Tested by:	11993
Date:	2020-02-05

Marker	Frequency (MHz)	Meter Reading (dBm)	Det	PL (dB)	Corrected Reading ERP (dBm)	ETSI EN Tx Spurious (dBm)	Margin (dB)	Azimuth (Degs)	Height (cm)	Polarity
1	181.9981	-63.29	Pk	-7.5	-70.79	-54	-16.79	0-360	98	H
2	206.0004	-66.58	Pk	-6.1	-72.68	-54	-18.68	0-360	102	H
3	854.7893	-78.23	Pk	5.8	-72.43	-54	-18.43	0-360	199	H
4	182.0193	-67.61	Pk	-4.1	-71.71	-54	-17.71	0-360	199	V
5	206.0004	-71.11	Pk	-3.6	-74.71	-54	-20.71	0-360	199	V
6	848.2889	-78.26	Pk	8.1	-70.16	-54	-16.16	0-360	101	V

Pk - Peak detector

RADIATED SPURIOUS EMISSIONS ABOVE 1 GHz

Project Number:	12777555
Client:	LEA
Test Location:	N-SAC
Mode:	1Tx, 11g, 2472MHz
Tested by:	11993
Date:	2020-02-04

Marker	Frequency (GHz)	Meter Reading (dBm)	Det	Path-Loss (dB)	Filter (dB)	Corrected Reading EIRP (dBm)	ETSI EN Tx Spurious (dBm)	Margin (dB)	Azimuth (Degs)	Height (cm)	Polarity
1	3.33443	-64.92	Pk	11.1	.6	-53.22	-30	-23.22	0-360	198	H
2	3.80151	-64.44	Pk	12.3	.4	-51.74	-30	-21.74	0-360	152	H
3	4.81842	-65.36	Pk	13.8	.4	-51.16	-30	-21.16	0-360	198	H
4	3.27764	-64.13	Pk	11.4	.7	-52.03	-30	-22.03	0-360	198	V
5	3.9528	-63.84	Pk	12.5	.4	-50.94	-30	-20.94	0-360	152	V
6	4.80961	-64.22	Pk	13.7	.4	-50.12	-30	-20.12	0-360	152	V

Pk - Peak detector

9.2. RECEIVER SPURIOUS EMISSIONS

LIMIT

ETSI EN 300 328 V2.1.1 (2016-11) Clause 4.3.2.10.3

The spurious emissions of the receiver shall not exceed the values given in table 13 below. In case of equipment with antenna connectors, these limits apply to emissions at the antenna port (conducted). For emissions radiated by the cabinet or for emissions radiated by integral antenna equipment (without antenna connectors), these limits are e.r.p. for emissions up to 1 GHz and e.i.r.p. for emissions above 1 GHz.

Table 13: Spurious emission limits for receivers

Frequency range	Maximum power	Bandwidth
30 MHz to 1 GHz	-57 dBm	100 kHz
1 GHz to 12,75 GHz	-47 dBm	1 MHz

TEST PROCEDURE

ETSI EN 300 328 V2.1.1 (2016-11) Clause 5.4.10

TEST CONDITION

ETSI EN 300 328 V2.1.1 (2016-11) Clause 5.4.10.1

The level of spurious emissions shall be measured as, either:

- a) their power in a specified load (conducted spurious emissions) and their effective radiated power when radiated by the cabinet or structure of the equipment (cabinet radiation); or
- b) their effective radiated power when radiated by cabinet and antenna in case of integral antenna equipment with no temporary antenna connectors.

Note: For testing the device covered by this report, test condition (a) was used. All measurements are PK, unless margin <-6dB, which warrants a follow-up RMS measurement.

9.2.1. RECEIVE MODE LOW CHANNEL 2412MHZ

RADIATED SPURIOUS EMISSIONS BELOW 1 GHz

Project Number:	12777555
Client:	LEA
Test Location:	N-SAC
Mode:	1Rx, 2412MHz
Tested by:	11993
Date:	2020-02-05

Marker	Frequency (MHz)	Meter Reading (dBm)	Det	PL (dB)	Corrected Reading ERP (dBm)	ETSI EN Rx Spurious (dBm)	Margin (dB)	Azimuth (Degs)	Height (cm)	Polarity
1	129.9859	-60.88	Pk	-5	-65.88	-57	-8.88	0-360	100	H
4	129.9859	-66.15	Pk	-1.1	-67.25	-57	-10.25	0-360	102	V
2	181.9981	-62.29	Pk	-7.5	-69.79	-57	-12.79	0-360	100	H
5	182.0193	-67.55	Pk	-4.1	-71.65	-57	-14.65	0-360	199	V
3	962.2457	-79.09	Pk	8.1	-70.99	-57	-13.99	0-360	102	H
6	991.1975	-78.88	Pk	11.4	-67.48	-57	-10.48	0-360	299	V

Pk - Peak detector

RADIATED SPURIOUS EMISSIONS ABOVE 1 GHz

Project Number:	12777555
Client:	LEA
Test Location:	N-SAC
Mode:	1Rx, 2412MHz
Tested by:	11993
Date:	2020-02-05

Marker	Frequency (GHz)	Meter Reading (dBm)	Det	Path-Loss (dB)	Corrected Reading EIRP (dBm)	ETSI EN Rx Spurious (dBm)	Margin (dB)	Azimuth (Degs)	Height (cm)	Polarity
1	2.26416	-64.03	Pk	8	-56.03	-47	-9.03	0-360	198	H
2	2.87665	-64.09	Pk	9.9	-54.19	-47	-7.19	0-360	152	H
3	4.71892	-75.81	RMS	13.6	-62.21	-47	-15.21	324	361	H
4	2.40223	-63.08	Pk	9.3	-53.78	-47	-6.78	0-360	198	V
5	2.92219	-64.24	Pk	10.6	-53.64	-47	-6.64	0-360	198	V
6	4.72055	-75.73	RMS	13.6	-62.13	-47	-15.13	6	383	V

Pk - Peak detector
 RMS - RMS detection

9.2.2 RECEIVE MODE LOW CHANNEL 2472MHZ
RADIATED SPURIOUS EMISSIONS BELOW 1 GHz

Project Number:	12777555
Client:	LEA
Test Location:	N-SAC
Mode:	1Tx, 2472MHz
Tested by:	11993
Date:	2020-02-05

Marker	Frequency (MHz)	Meter Reading (dBm)	Det	PL (dB)	Corrected Reading ERP (dBm)	ETSI EN Rx Spurious (dBm)	Margin (dB)	Azimuth (Degs)	Height (cm)	Polarity
4	80.8006	-62.5	Pk	-8.9	-71.4	-57	-14.4	0-360	199	V
1	129.9859	-59.05	Pk	-5	-64.05	-57	-7.05	0-360	98	H
5	129.9859	-62.53	Pk	-1.1	-63.63	-57	-6.63	0-360	102	V
2	181.9981	-61.37	Pk	-7.5	-68.87	-57	-11.87	0-360	98	H
6	956.4954	-78.23	Pk	10.8	-67.43	-57	-10.43	0-360	101	V
3	984.2971	-78.7	Pk	8.4	-70.3	-57	-13.3	0-360	199	H

Pk - Peak detector

RADIATED SPURIOUS EMISSIONS ABOVE 1 GHz

Project Number:	12777555
Client:	LEA
Test Location:	N-SAC
Mode:	1Tx, 2472MHz
Tested by:	11993
Date:	2020-02-05

Marker	Frequency (GHz)	Meter Reading (dBm)	Det	Path-Loss (dB)	Corrected Reading EIRP (dBm)	ETSI EN Rx Spurious (dBm)	Margin (dB)	Azimuth (Degs)	Height (cm)	Polarity
1	2.10822	-63.31	Pk	7	-56.31	-47	-9.31	0-360	198	H
2	2.5682	-64.14	Pk	8.9	-55.24	-47	-8.24	0-360	198	H
3	4.8238	-75.74	RMS	13.8	-61.94	-47	-14.94	332	255	H
4	1.57431	-60.84	Pk	3.8	-57.04	-47	-10.04	0-360	152	V
5	2.81496	-63.84	Pk	10.2	-53.64	-47	-6.64	0-360	152	V
6	4.82322	-75.63	RMS	13.8	-61.83	-47	-14.83	46	214	V

Pk - Peak detector
 RMS - RMS detection

10. SETUP PHOTOS

RADIATED SPURIOUS EMISSIONS

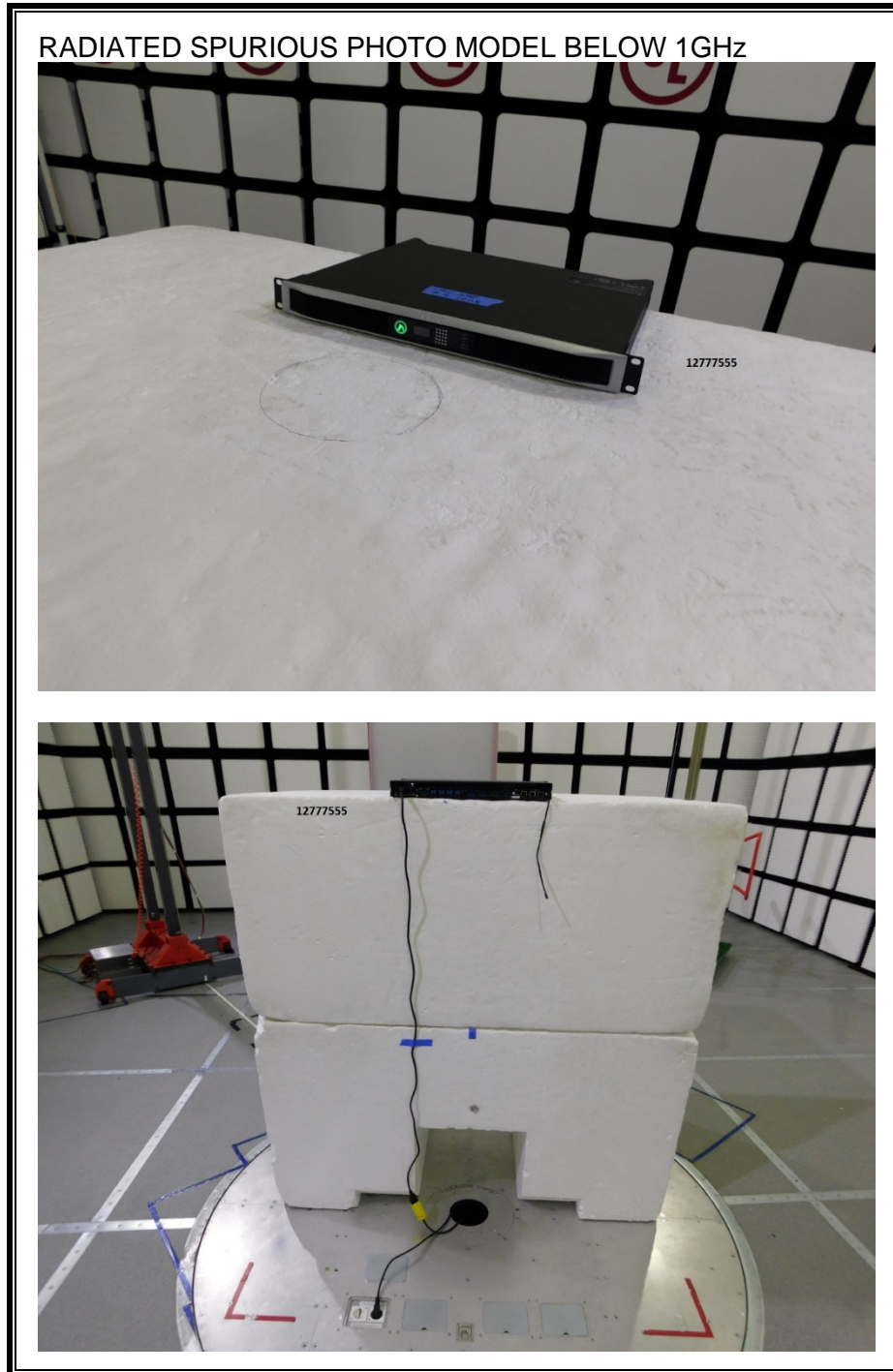

RADIATED SPURIOUS BACK PHOTO ABOVE 1GHz

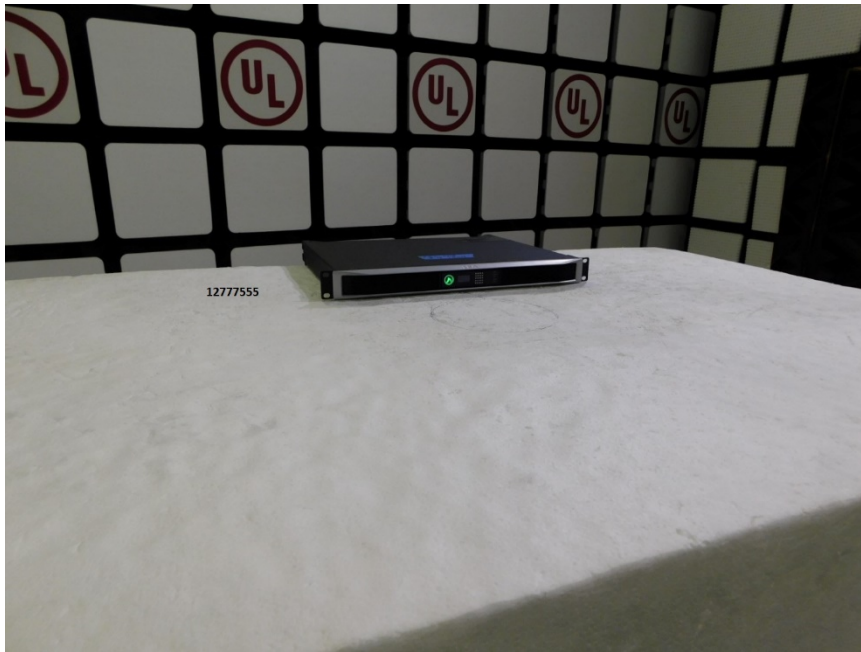
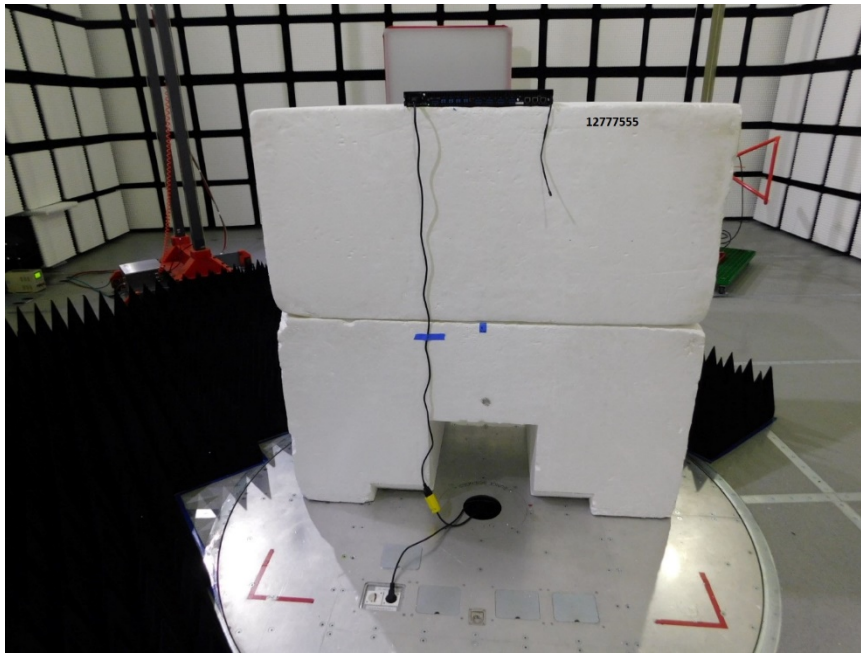

END OF TEST REPORT